

# RESTRAINT SYSTEM

# SECTION RS

## CONTENTS

<b>SEAT BELTS</b> .....	3	INSTALLATION.....	22	CL
Precautions.....	3	Front Passenger Air Bag Module.....	22	
SUPPLEMENTAL RESTRAINT SYSTEM (SRS)		REMOVAL.....	22	MT
“AIR BAG” AND “SEAT BELT PRE-TENSIONER”.....	3	INSTALLATION.....	23	
PRECAUTION FOR SEAT BELT SERVICE.....	3	Side Air Bag Module.....	24	AT
Front Seat Belt.....	5	REMOVAL.....	24	
REMOVAL AND INSTALLATION.....	5	INSTALLATION.....	25	
Rear Seat Belt.....	7	Disposal of Air Bag Module and Seat Belt Pre-		
REMOVAL AND INSTALLATION.....	7	tensioner.....	25	AX
Seat Belt Inspection.....	9	CHECKING DEPLOYMENT TOOL.....	26	
AFTER A COLLISION.....	9	DEPLOYMENT PROCEDURES FOR AIR BAG		
PRELIMINARY CHECKS.....	9	MODULE (OUTSIDE OF VEHICLE).....	27	SU
SEAT BELT RETRACTOR ON-VEHICLE CHECK.....	10	DEPLOYMENT PROCEDURES FOR SEAT BELT		
SEAT BELT RETRACTOR OFF-VEHICLE CHECK.....	10	PRE-TENSIONER (OUTSIDE OF VEHICLE).....	29	BR
Tether Anchor Plate.....	12	DEPLOYMENT OF AIR BAG MODULE AND SEAT		
REMOVAL AND INSTALLATION.....	12	BELT PRE-TENSIONER WHILE MOUNTED IN		
<b>SUPPLEMENTAL RESTRAINT SYSTEM (SRS)</b> .....	13	VEHICLE.....	30	ST
Precautions.....	13	DISPOSING OF AIR BAG MODULE AND SEAT		
SUPPLEMENTAL RESTRAINT SYSTEM (SRS)		BELT PRE-TENSIONER.....	30	
“AIR BAG” AND “SEAT BELT PRE-TENSIONER”.....	13	Trouble Diagnoses Introduction.....	32	RS
PRECAUTIONS FOR SRS “AIR BAG” AND “SEAT		DIAGNOSIS FUNCTION.....	32	
BELT PRE-TENSIONER” SERVICE.....	13	DIAGNOSIS MODE FOR CONSULT-II.....	32	BT
WIRING DIAGRAMS AND TROUBLE DIAGNOSIS.....	13	Ⓜ HOW TO CHANGE SELF-DIAGNOSIS MODE		
Preparation.....	14	WITH CONSULT-II.....	33	
SPECIAL SERVICE TOOLS.....	14	ⓧ HOW TO CHANGE SELF-DIAGNOSIS MODE		
COMMERCIAL SERVICE TOOL.....	15	WITHOUT CONSULT-II.....	33	HA
SRS Configuration.....	15	HOW TO ERASE SELF-DIAGNOSIS RESULTS.....	33	
Seat Belt Pre-tensioner with Load Limiter.....	16	How to Perform Trouble Diagnoses for Quick		
Built-in Type Side Air Bag.....	16	and Accurate Repair.....	35	SC
SRS Component Parts Location.....	17	INFORMATION FROM CUSTOMER.....	35	
Maintenance Items.....	17	PRELIMINARY CHECK.....	35	EL
Diagnosis Sensor Unit.....	18	WORK FLOW.....	36	
REMOVAL AND INSTALLATION.....	18	Schematic.....	37	
Seat Belt Pre-tensioner.....	19	Wiring Diagram - SRS -.....	38	IDX
REMOVAL AND INSTALLATION.....	19	SRS Operation Check.....	41	
Satellite Sensor.....	19	DIAGNOSTIC PROCEDURE 1.....	41	
REMOVAL AND INSTALLATION.....	19	Ⓜ Trouble Diagnoses with CONSULT-II.....	42	
Driver Air Bag Module and Spiral Cable.....	20	DIAGNOSTIC PROCEDURE 2.....	42	
REMOVAL AND INSTALLATION.....	20	DIAGNOSTIC PROCEDURE 3.....	45	
REMOVAL.....	20	DIAGNOSTIC PROCEDURE 4 (CONTINUED		
		FROM DIAGNOSTIC PROCEDURE 2).....	47	

# CONTENTS (Cont'd)

DIAGNOSTIC PROCEDURE 5.....	47	DIAGNOSTIC PROCEDURE 9.....	59
⊗ Trouble Diagnoses without CONSULT-II.....	51	Trouble Diagnoses: "AIR BAG" Warning Lamp	
DIAGNOSTIC PROCEDURE 6.....	51	Does Not Turn On .....	61
DIAGNOSTIC PROCEDURE 7.....	56	DIAGNOSTIC PROCEDURE 10 .....	61
DIAGNOSTIC PROCEDURE 8 (CONTINUED		Collision Diagnosis .....	62
FROM DIAGNOSTIC PROCEDURE 6) .....	58	FOR FRONTAL COLLISION .....	62
Trouble Diagnoses: "AIR BAG" Warning Lamp		FOR SIDE COLLISION.....	64
Does Not Turn Off .....	59		

## Precautions

**SUPPLEMENTAL RESTRAINT SYSTEM (SRS) “AIR BAG” AND “SEAT BELT PRE-TENSIONER”**

NFRS0001

The Supplemental Restraint System such as “AIR BAG” and “SEAT BELT PRE-TENSIONER” used along with a seat belt, helps to reduce the risk or severity of injury to the driver and front passenger for certain types of collision. The SRS composition which is available to NISSAN MODEL A33 is as follows (The composition varies according to the optional equipment):

- For a frontal collision  
The Supplemental Restraint System consists of driver air bag module (located in the center of the steering wheel), front passenger air bag module (located on the instrument panel on passenger side), seat belt pre-tensioners, a diagnosis sensor unit, warning lamp, wiring harness and spiral cable.
- For a side collision  
The Supplemental Restraint System consists of front side air bag module (located in the outer side of front seat), satellite sensor, diagnosis sensor unit (one of components of air bags for a frontal collision), wiring harness, warning lamp (one of components of air bags for a frontal collision).

**WARNING:**

- To avoid rendering the SRS inoperative, which could increase the risk of personal injury or death in the event of a collision which would result in air bag inflation, all maintenance should be performed by an authorized NISSAN dealer.
- Improper maintenance, including incorrect removal and installation of the SRS, can lead to personal injury caused by unintentional activation of the system.
- Do not use electrical test equipment on any circuit related to the SRS unless instructed to in this Service Manual. Spiral cable and wiring harnesses covered with yellow insulation tape either just before the harness connectors or for the complete harness are related to the SRS.

**PRECAUTION FOR SEAT BELT SERVICE**

NFRS0002

**CAUTION:**

- Before removing the seat belt pre-tensioner assembly, turn the ignition switch off, disconnect both battery cables and wait at least 3 minutes.
- Do not use electrical test equipment for seat belt pre-tensioner connector.
- After replacing or reinstalling seat belt pre-tensioner assembly, or reconnecting seat belt pre-tensioner connector, check the system function. Refer to “SRS Operation Check” for details. (RS-41)
- Do not use disassemble buckle or seat belt assembly.
- Replace anchor bolts if they are deformed or worn out.
- Never oil tongue and buckle.
- If any component of seat belt assembly is questionable, do not repair. Replace the whole seat belt assembly.
- If webbing is cut, frayed, or damaged, replace seat belt assembly.
- When replacing seat belt assembly, use a genuine seat belt assembly.

**After A Collision**

NFRS0002S01

**WARNING:**

Inspect all seat belt assemblies including retractors and attaching hardware after any collision. NISSAN recommends that all seat belt assemblies in use during a collision be replaced unless the collision was minor and the belts show no damage and continue to operate properly. Failure to do so could result in serious personal injury in an accident. Seat belt assemblies not in use during a collision should also be replaced if either damage or improper operation is noted. Seat belt pre-tensioner should be replaced even if the seat belts are not in use during a frontal collision in which the air bags are deployed.

Replace any seat belt assembly if:

- The seat belt was in use at the time of a collision (except for minor collisions and the belts, retractors and buckles show no damage and continue to operate properly).
- The seat belt was damaged in an accident. (i.e. torn webbing, bent retractor or guide, etc.)
- The seat belt attaching point was damaged in an accident. Inspect the seat belt attaching area for damage or distortion and repair as necessary before installing a new seat belt assembly.
- Anchor bolts are deformed or worn out.

## SEAT BELTS

### *Precautions (Cont'd)*

---

- The seat belt pre-tensioner should be replaced even if the seat belts are not in use during the collision in which the air bags are deployed.

## Front Seat Belt

### REMOVAL AND INSTALLATION

=NFRS0003

1. Slide the seat all the way forward and tilt the seatback toward the front.
2. Remove adjuster cover. **A**
3. Slide floor anchor cover.
4. Remove floor anchor bolt. **B**
5. Remove shoulder anchor bolt. **C**
6. Remove front and rear kicking plate, then remove center pillar upper and lower garnish. Refer to BT-32, "SIDE AND FLOOR TRIM" for details.
7. Disconnect seat belt pre-tensioner connector.
8. Remove the screw securing seat belt pre-tensioner retractor, then remove seat belt and seat belt pre-tensioner retractor.
9. Remove bolts securing seat belt adjuster, then remove seat belt adjuster.

#### SEC. 796•868

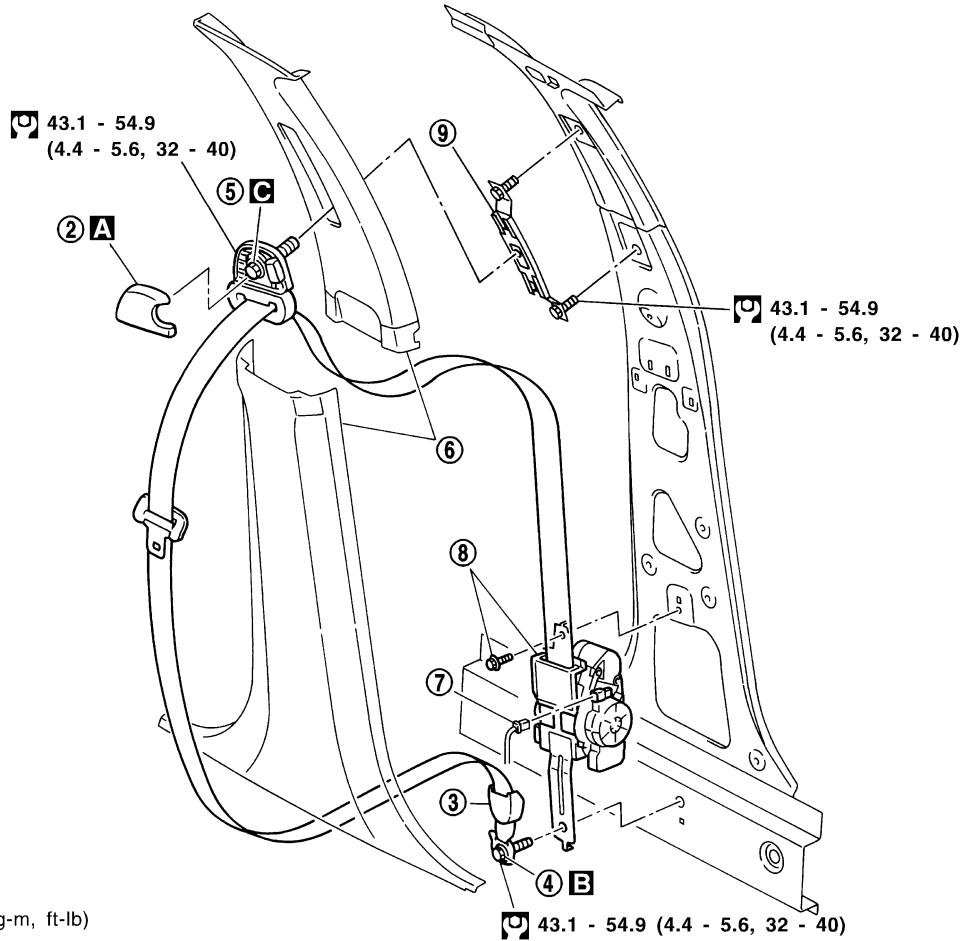

: N·m (kg-m, ft-lb)

43.1 - 54.9 (4.4 - 5.6, 32 - 40)

SRS714-A

GI  
MA  
EM  
LC  
EC  
FE  
CL  
MT  
AT  
AX  
SU  
BR  
ST  
RS  
BT  
HA  
SC  
EL  
IDX

# SEAT BELTS

Front Seat Belt (Cont'd)

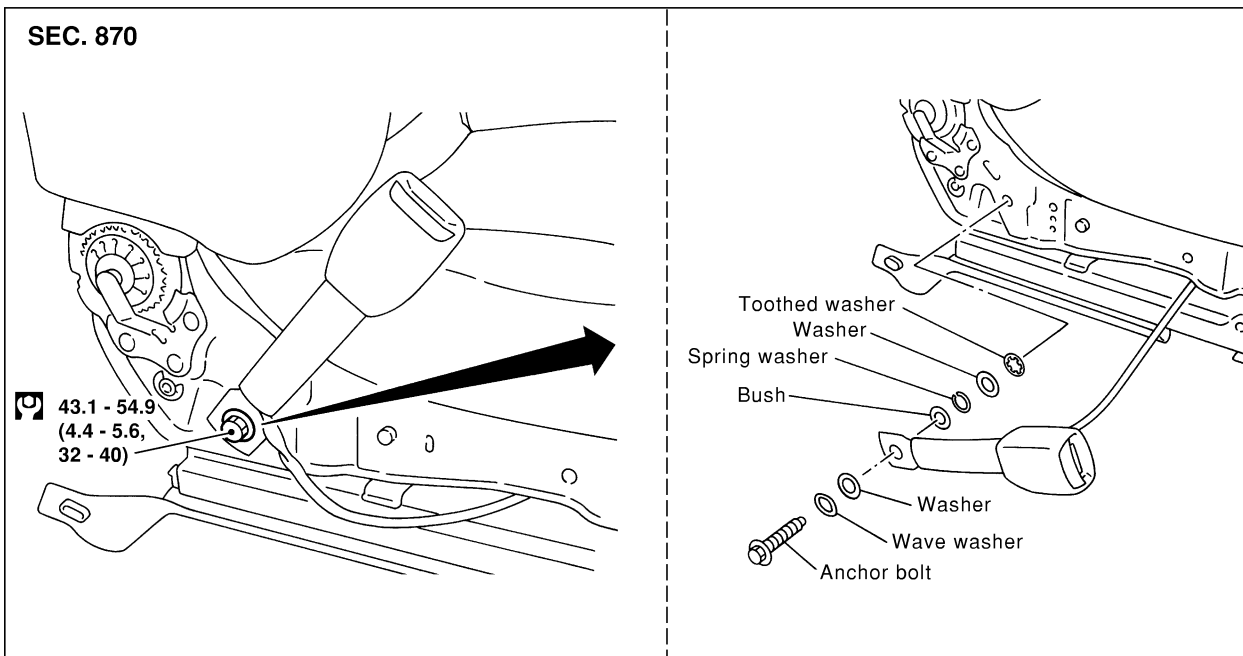
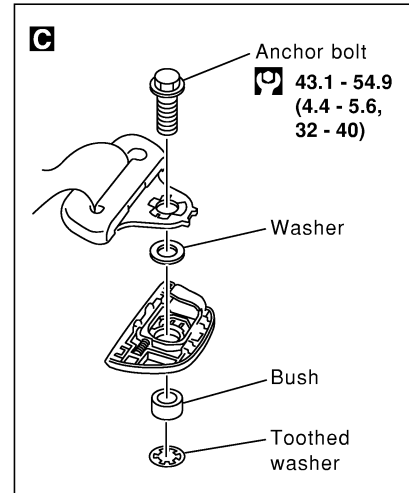
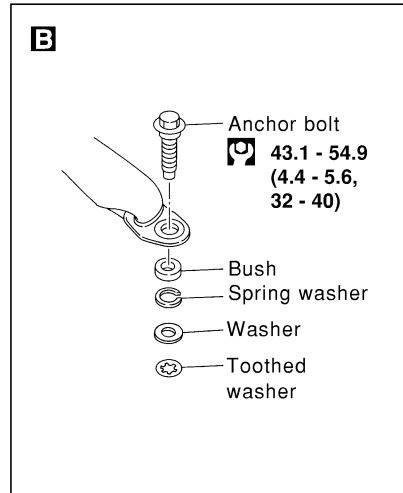
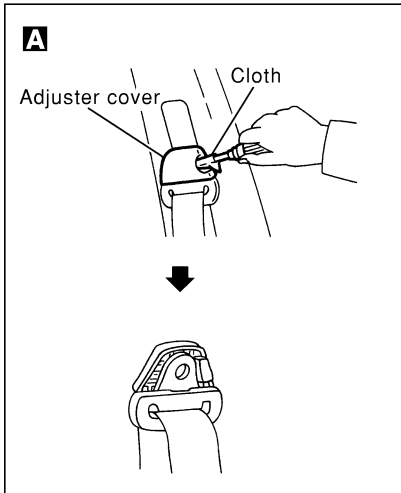

: N•m (kg-m, ft-lb)

SRS789

# SEAT BELTS

Rear Seat Belt

## Rear Seat Belt

### REMOVAL AND INSTALLATION

=NFRS0004

1. Remove rear seat. Refer to BT-50, "REAR SEAT" for details.
2. Remove outer and floor anchor bolt. **A B**
3. Remove rear side garnish. Refer to BT-32, "SIDE AND FLOOR TRIM" for details.
4. Remove rear parcel shelf finisher. Refer to BT-32, "SIDE AND FLOOR TRIM" for details.
5. Remove bolts securing rear seat belt retractor, then remove seat belt and seat belt retractor. **C**

SEC. 869

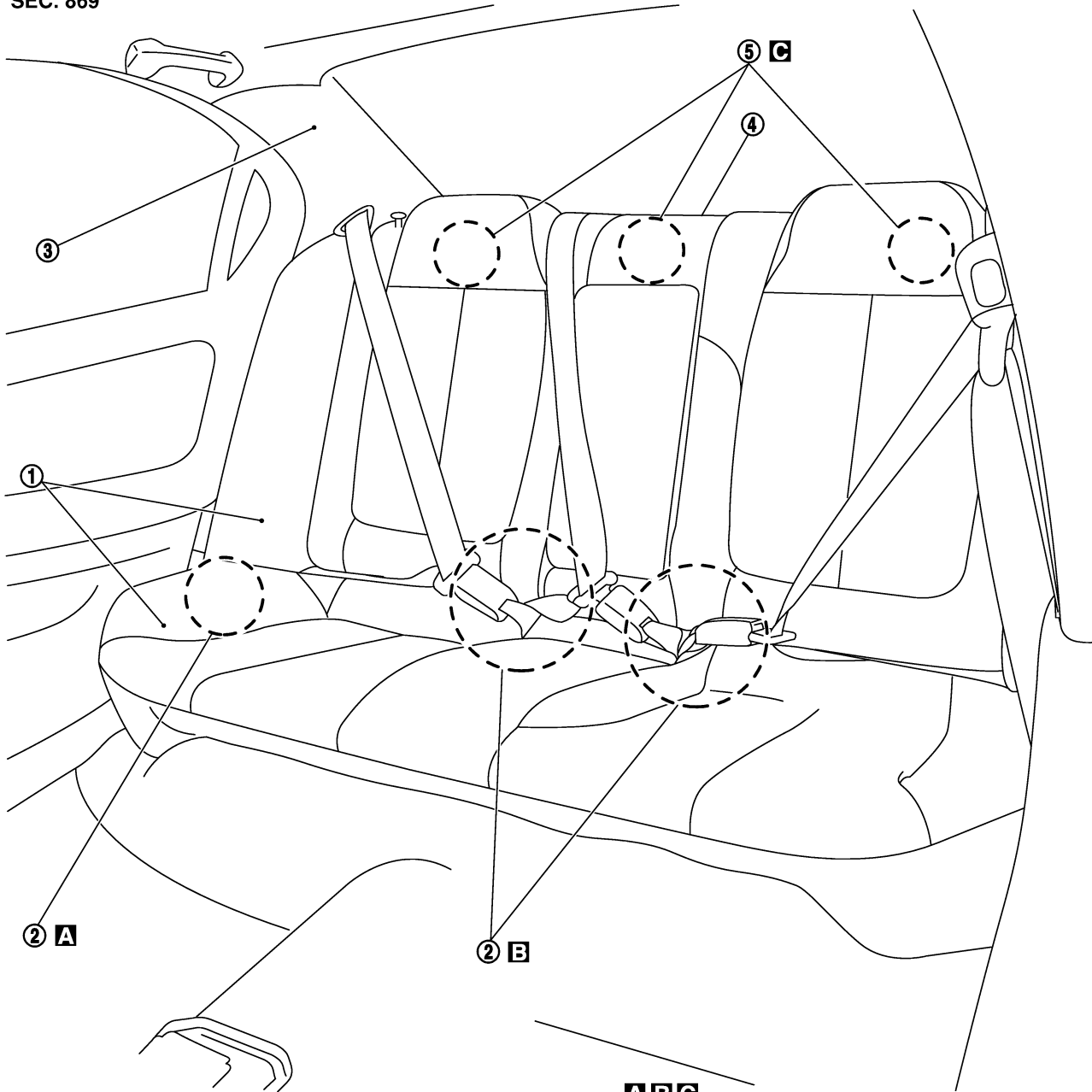

**A B C**

 43.1 - 54.9 N·m (4.4 - 5.6 kg·m, 32 - 40 ft·lb)

SRS716-A

GI

MA

EM

LC

EC

FE

CL

MT

AT

AX

SU

BR

ST

**RS**

BT

HA

SC

EL

IDX

# SEAT BELTS

## Rear Seat Belt (Cont'd)

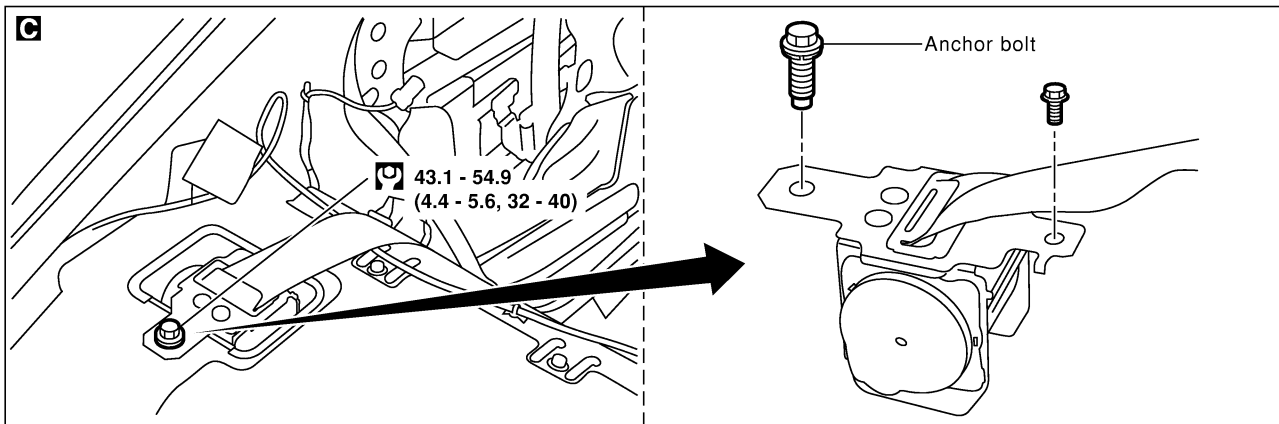
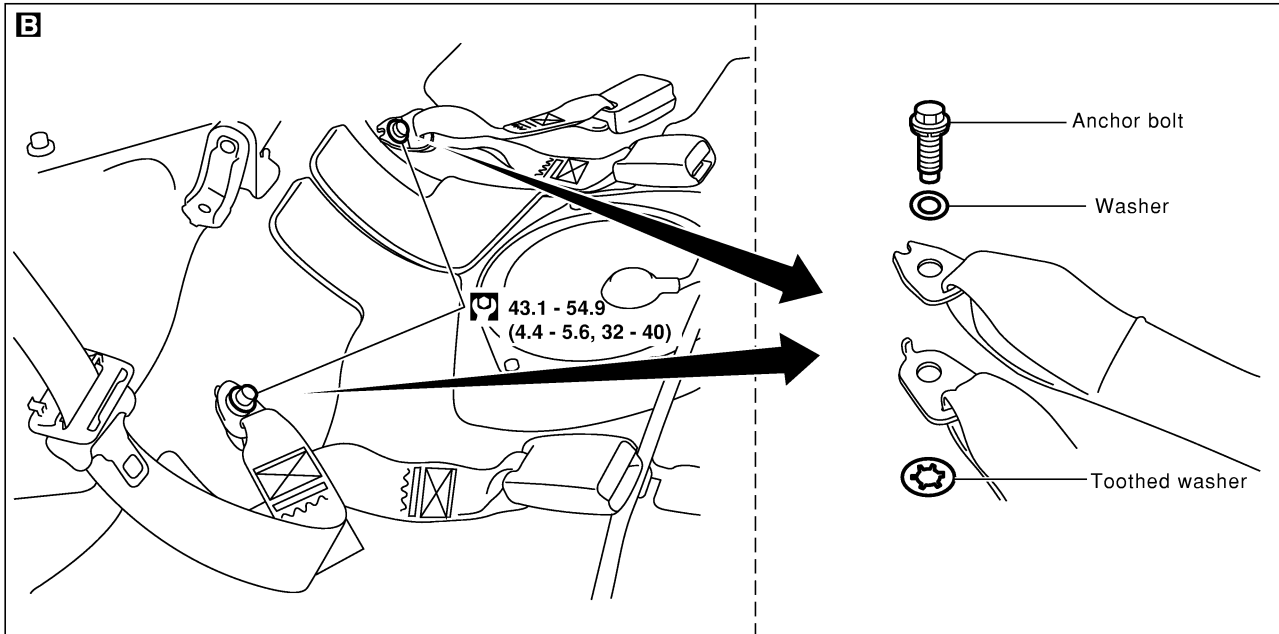
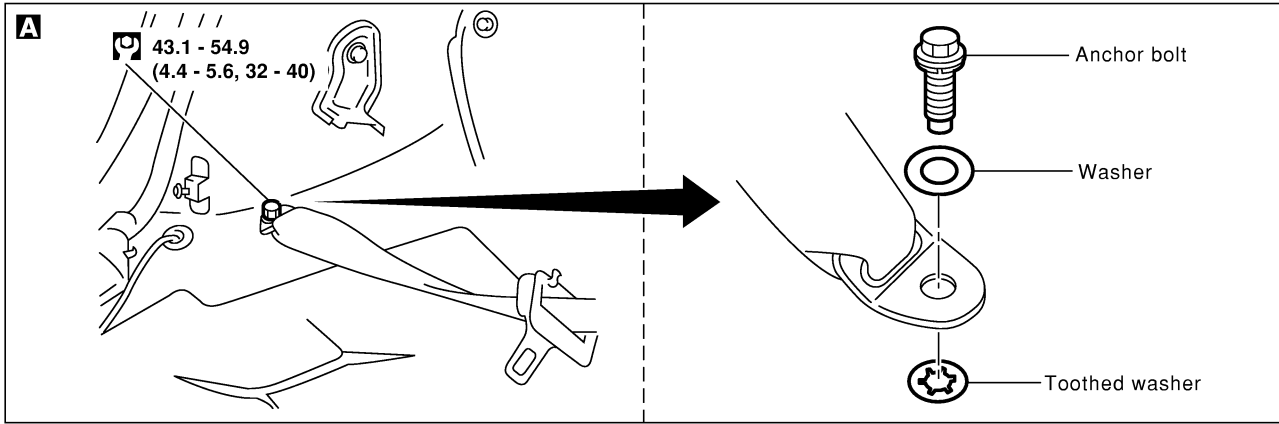

 : N·m (kg-m, ft-lb)



## Seat Belt Inspection

=NFRS0052

NFRS0052S01

## AFTER A COLLISION

**WARNING:**

Inspect all seat belt assemblies including retractors and attaching hardware after any collision. NISSAN recommends that all seat belt assemblies in use during a collision be replaced unless the collision was minor and the belts show no damage and continue to operate properly. Failure to do so could result in serious personal injury in an accident. Seat belt assemblies not in use during a collision should also be replaced if either damage or improper operation is noted. Seat belt pre-tensioner should be replaced even if the seat belts are not in use during a frontal collision in which the air bags are deployed.

Replace any seat belt assembly if:

- The seat belt was in use at the time of a collision (except for minor collisions and the belts, retractors and buckles show no damage and continue to operate properly).
- The seat belt was damaged in an accident. (i.e. torn webbing, bent retractor or guide, etc.)
- The seat belt attaching point was damaged in an accident. Inspect the seat belt attaching area for damage or distortion and repair as necessary before installing a new seat belt assembly.
- Anchor bolts are deformed or worn out.
- The seat belt pre-tensioner should be replaced even if the seat belts are not in use during the collision in which the air bags are deployed.

## PRELIMINARY CHECKS

NFRS0052S02

1. Check the air bag warning lamp/chime for proper operation as follows:
  - a. Switch ignition ON. The air bag warning lamp should illuminate. Also, the air bag warning chime should sound for about seven seconds.
  - b. Fasten driver's seat belt. The seat belt warning lamp should go out and the chime (if sounding) should stop.
  - c. If the air bag warning lamp is blinking, conduct self-diagnosis using CONSULT-II, and air bag warning lamp. Refer to "SRS Operation Check", RS-41.
2. Check that the seat belt retractor, seat belt anchor and buckle bolts are securely attached.
3. Check the shoulder seat belt guide and shoulder belt height adjuster for front seats. Ensure guide swivels freely and that belt lays flat and does not bind in guide. Ensure height adjuster operates properly and holds securely.
4. Check retractor operation:
  - a. Fully extend the seat belt webbing and check for twists, tears or other damage.
  - b. Allow the seat belt to retract. Ensure that belt returns smoothly and completely into the retractor. If the seat belt does not return smoothly, wipe the inside of the loops with a clean paper cloth etc. because dirt built up in the loops of the upper anchors can cause the seat belts to retract slowly.
  - c. Fasten the seat belt. Pull firmly on belt and buckle to ensure belt remains latched. Unfasten seat belt. Ensure belt releases freely and buckle button returns to original position.

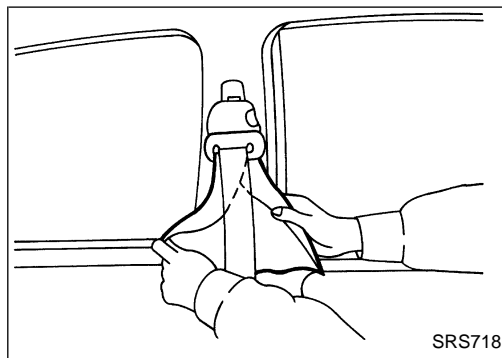

5. Repeat steps above as necessary to check the other seat belts.

# SEAT BELTS

Seat Belt Inspection (Cont'd)

## SEAT BELT RETRACTOR ON-VEHICLE CHECK

NFRS0052S03

### Emergency Locking Retractors (ELR) and Automatic Locking Retractors (ALR)

NFRS0052S0301

#### NOTE:

All seat belt retractors are of the Emergency Locking Retractors (ELR) type. In an emergency (sudden stop) the retractor will lock and prevent the belt from extending any further. All 3-point type seat belt retractors except the driver's seat belt also have an Automatic Locking Retractors (ALR) mode. The ALR mode (also called child restraint mode) is used when installing child seats. The ALR mode is activated when the seat belt is fully extended. When the belt is then retracted partially, the ALR mode automatically locks the seat belt in a specific position so the belt cannot be extended any further. To cancel the ALR mode, allow the seat belt to fully wind back into the retractor.

Check the seat belt retractors using the following test(s) to determine if a retractor assembly is operating properly.

#### ELR Function Stationary Check

NFRS0052S0302

Grasp the shoulder belt and pull forward quickly. The retractor should lock and prevent the belt from extending further.

#### ALR Function Stationary Check

NFRS0052S0303

1. Pull out entire length of seat belt from retractor until a click is heard.
2. Retract the belt partially. A clicking noise should be heard as the belt retracts indicating that the retractor is in the Automatic Locking Retractors (ALR) mode.
3. Grasp the seat belt and try to pull out the retractor. The belt must lock and not extend any further. If NG, replace the retractor assembly.
4. Allow the entire length of the belt to retract to cancel the automatic locking mode.

#### ELR Function Moving Check

NFRS0052S0304

#### WARNING:

Perform the following test in a safe, open area clear of other vehicles and obstructions (for example, a large, empty parking lot). Road surface must be paved and dry. DO NOT perform the following test on wet or gravel roads or on public streets and highways. This could result in an accident and serious personal injury. The driver and passenger must be prepared to brace themselves in the event the retractor does not lock.

1. Fasten driver's seat belt. Buckle a passenger into the seat for the belt that is to be tested.
2. Proceed to the designated safe area.
3. Drive the vehicle at approximately 16 km/h (10 MPH). Notify any passengers of a pending sudden stop and the driver and passenger must be prepared to brace themselves in the event the retractor does not lock, apply brakes firmly and make a very hard stop.

During stop, seat belts should lock and not be extended. If the seat belt retractor assembly does not lock, perform the retractor off-vehicle check.

## SEAT BELT RETRACTOR OFF-VEHICLE CHECK

NFRS0052S04

1. Remove the seat belt retractor assembly.
2. Slowly pull out belt while tilting the retractor assembly forward from the mounted position without twisting the retractor assembly as shown in the illustration.

**15 degrees or less tilt: Belt can be pulled out.**

**35 degrees or more tilt: Belt locks and cannot be pulled out.**

# SEAT BELTS

Seat Belt Inspection (Cont'd)

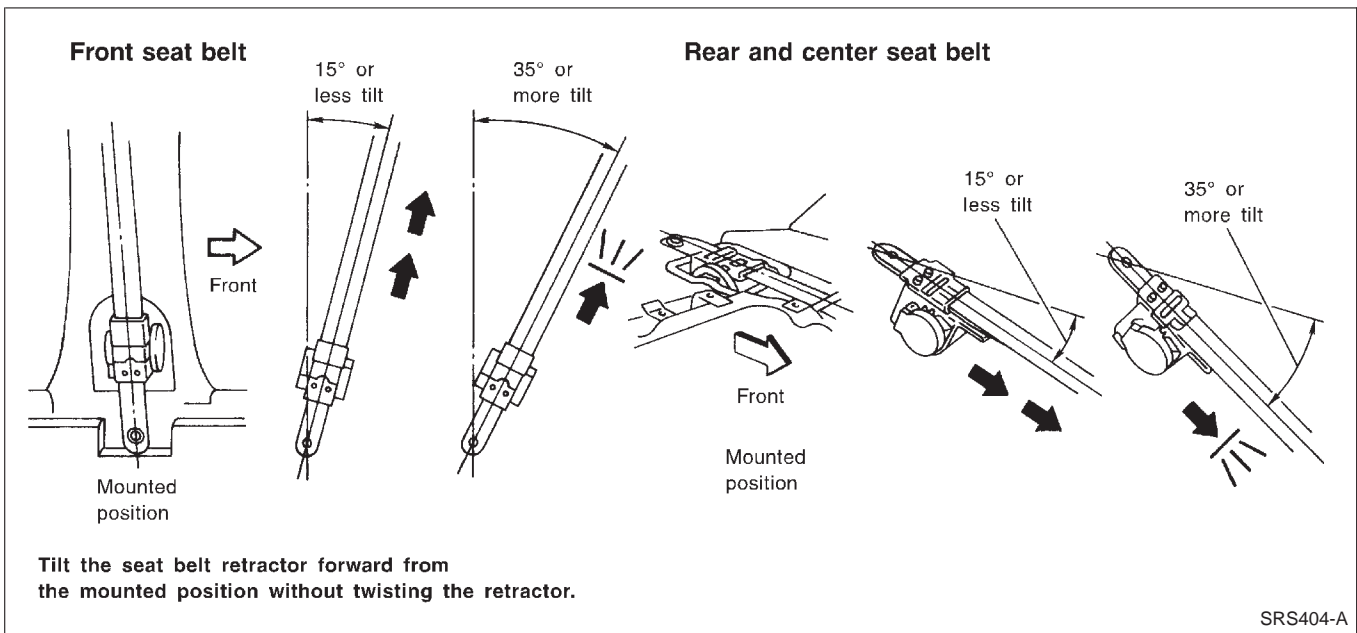

If NG, replace the retractor assembly.

GI

MA

EM

LC

EC

FE

CL

MT

AT

AX

SU

BR

ST

**RS**

BT

HA

SC

EL

IDX

# SEAT BELTS

Tether Anchor Plate

## Tether Anchor Plate

### REMOVAL AND INSTALLATION

=NFRS0039

#### CAUTION:

Replace anchor bolts if they are deformed or worn out.

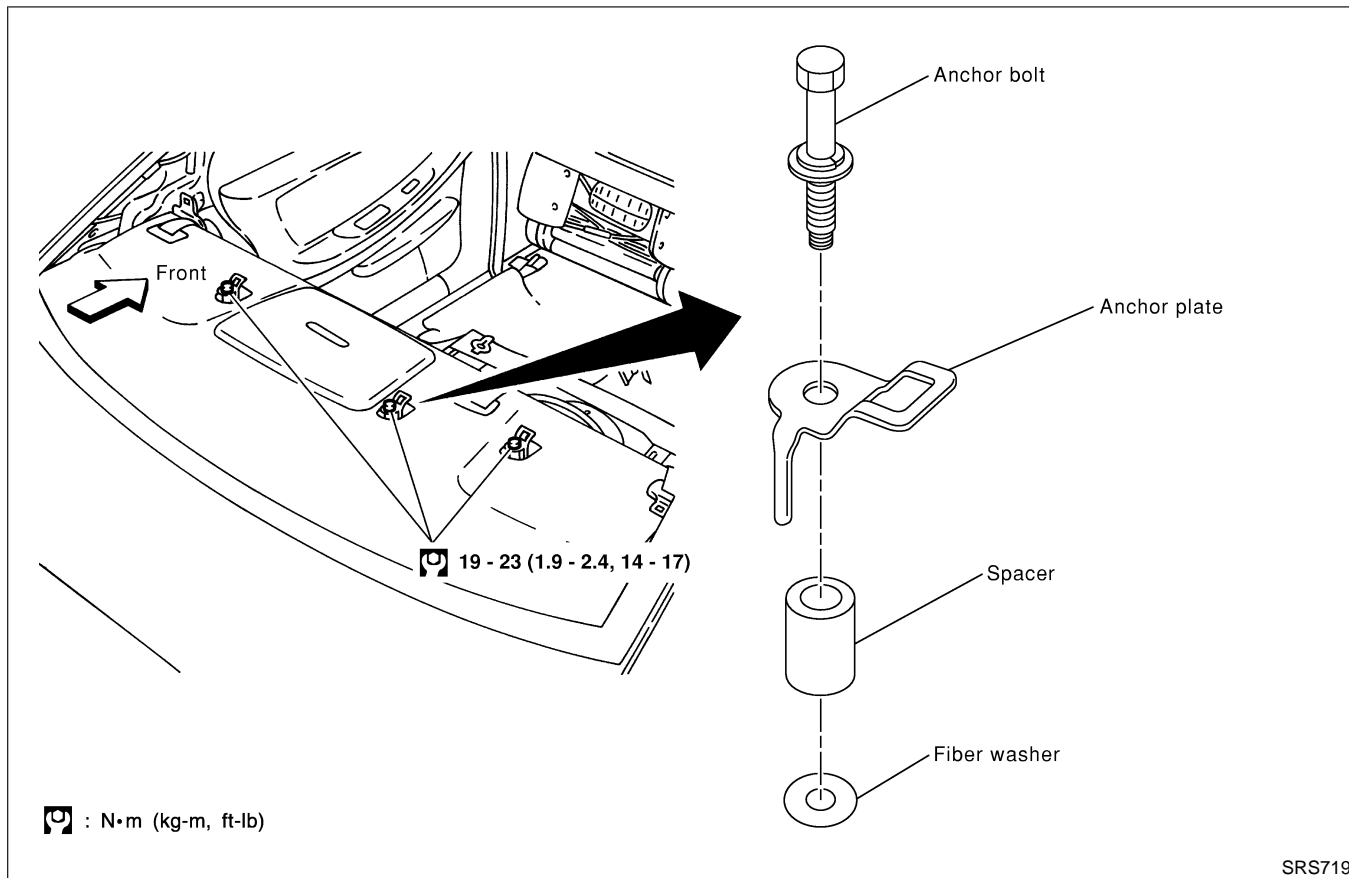

SRS719

1. Remove tether anchor plate cover. Refer to BT-32, "SIDE AND FLOOR TRIM" for details.
2. Remove tether anchor plate.

#### NOTE:

- To install, reverse the removal procedure sequence.

## Precautions

### SUPPLEMENTAL RESTRAINT SYSTEM (SRS) “AIR BAG” AND “SEAT BELT PRE-TENSIONER”

The Supplemental Restraint System such as “AIR BAG” and “SEAT BELT PRE-TENSIONER” used along with a seat belt, helps to reduce the risk or severity of injury to the driver and front passenger for certain types of collision. The SRS composition which is available to NISSAN MODEL A33 is as follows (The composition varies according to the optional equipment):

- For a frontal collision  
The Supplemental Restraint System consists of driver air bag module (located in the center of the steering wheel), front passenger air bag module (located on the instrument panel on passenger side), seat belt pre-tensioners, a diagnosis sensor unit, warning lamp, wiring harness and spiral cable.
- For a side collision  
The Supplemental Restraint System consists of front side air bag module (located in the outer side of front seat), satellite sensor, diagnosis sensor unit (one of components of air bags for a frontal collision), wiring harness, warning lamp (one of components of air bags for a frontal collision).

#### WARNING:

- To avoid rendering the SRS inoperative, which could increase the risk of personal injury or death in the event of a collision which would result in air bag inflation, all maintenance should be performed by an authorized NISSAN dealer.
- Improper maintenance, including incorrect removal and installation of the SRS, can lead to personal injury caused by unintentional activation of the system.
- Do not use electrical test equipment on any circuit related to the SRS unless instructed to in this Service Manual. Spiral cable and wiring harnesses covered with yellow insulation tape either just before the harness connectors or for the complete harness are related to the SRS.

### PRECAUTIONS FOR SRS “AIR BAG” AND “SEAT BELT PRE-TENSIONER” SERVICE

- Do not use electrical test equipment to check SRS circuits unless instructed to in this Service Manual.
- Before servicing the SRS, turn ignition switch “OFF”, disconnect both battery cables and wait at least 3 minutes.  
For approximately 3 minutes after the cables are removed, it is still possible for the air bag and seat belt pre-tensioner to deploy. Therefore, do not work on any SRS connectors or wires until at least 3 minutes have passed.
- Diagnosis sensor unit must always be installed with their arrow marks “⇐” pointing towards the front of the vehicle for proper operation. Also check diagnosis sensor unit for cracks, deformities or rust before installation and replace as required.
- The spiral cable must be aligned with the neutral position since its rotations are limited. Do not attempt to turn steering wheel or column after removal of steering gear.
- Handle air bag module carefully. Always place driver and passenger air bag modules with the pad side facing upward and place side air bag module (built-in type) standing with stud bolt side setting bottom.
- Conduct self-diagnosis to check entire SRS for proper function after replacing any components.
- After air bag inflates, the front instrument panel assembly should be replaced if damaged.

### WIRING DIAGRAMS AND TROUBLE DIAGNOSIS

When you read wiring diagrams, refer to the following:

- GI-11, “HOW TO READ WIRING DIAGRAMS”
- EL-9, “POWER SUPPLY ROUTING” for power distribution circuit

When you perform trouble diagnosis, refer to the following:

- GI-36, “HOW TO FOLLOW TEST GROUP IN TROUBLE DIAGNOSES”
- GI-25, “HOW TO PERFORM EFFICIENT DIAGNOSIS FOR AN ELECTRICAL INCIDENT”

GI  
MA  
EM  
LC  
EC  
FE  
CL  
MT  
AT  
AX  
SU  
BR  
ST  
RS  
BT  
HA  
SC  
EL  
IDX

# SUPPLEMENTAL RESTRAINT SYSTEM (SRS)

Preparation

## Preparation

### SPECIAL SERVICE TOOLS

=NFRS0009

The actual shapes of Kent-Moore tools may differ from those of special service tools illustrated here.

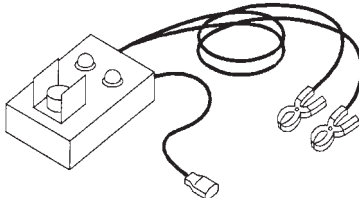
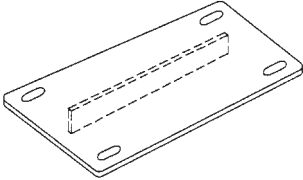
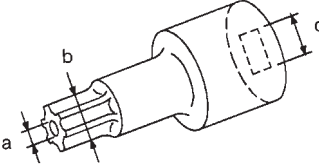
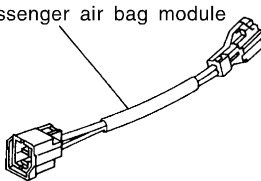
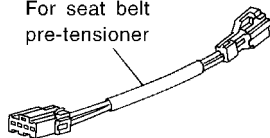
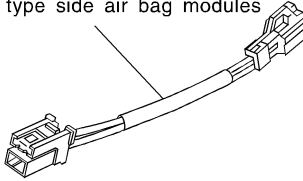
Tool number (Kent-Moore No.) Tool name	Description	
KV99106400 (J38381) Deployment tool	 <p>NT357</p>	Disposing of air bag module
KV99105300 (J41246) Air bag module bracket	 <p>NT354</p>	Anchoring air bag module
HT61961000 and HT62152000 combined (J38219) *Special torx bit	 <p>NT361</p>	Use for special bolts [TAMPER RESISTANT TORX (Size T50)] <b>a: 3.5 (0.138) dia.</b> <b>b: 8.5 - 8.6 (0.335 - 0.339) dia.</b> <b>c: approx. 10 (0.39) sq.</b> Unit: mm (in)
KV99108300 (J38381-35) Deployment tool adapter for passenger air bag	 <p>For passenger air bag module</p> <p>NT775</p>	
KV99108200 (J38381-50) Deployment tool adapter for seat belt pre-tensioner	 <p>For seat belt pre-tensioner</p> <p>NT721</p>	
KV99109000 (J44230) Deployment tool adapters for built-in type side air bag	 <p>For built-in type side air bag modules</p> <p>NT767</p>	

\*: Special tool or commercial equivalent

# SUPPLEMENTAL RESTRAINT SYSTEM (SRS)

Preparation (Cont'd)

## COMMERCIAL SERVICE TOOL

NFRS0040

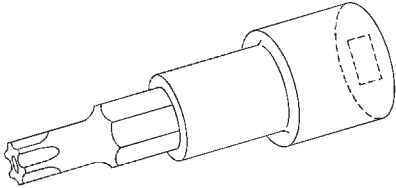
Tool name	Description
Tamper resistant torx socket	Size: T30 
	NT757

GI

MA

EM

LC

EC

## SRS Configuration

NFRS0010

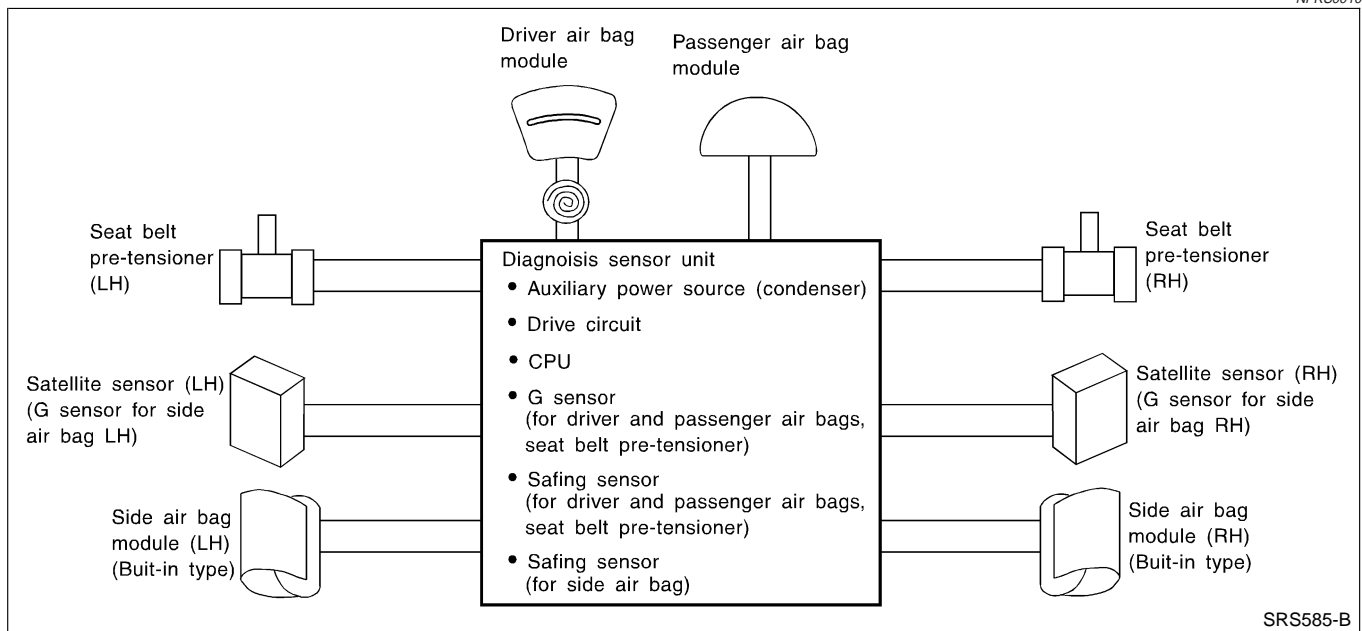

FE

CL

MT

AT

AX

SU

BR

The air bag deploys if the diagnosis sensor unit activates while the ignition switch is in the "ON" or "START" position.

The collision modes for which supplemental restraint systems are activated are different among the SRS systems. For example, the driver air bag module and passenger air bag module are activated in a frontal collision but not in a side collision.

SRS configurations which are activated for some collision modes are as follows;

SRS configuration	Frontal collision	Left side collision	Right side collision
Driver air bag module	○	—	—
Passenger air bag module	○	—	—
Seat belt pre-tensioner (LH)	○	—	—
Seat belt pre-tensioner (RH)	○	—	—
Side air bag module (LH)	—	○	—
Side air bag module (RH)	—	—	○

ST

RS

BT

HA

SC

EL

IDX

# SUPPLEMENTAL RESTRAINT SYSTEM (SRS)

## Seat Belt Pre-tensioner with Load Limiter

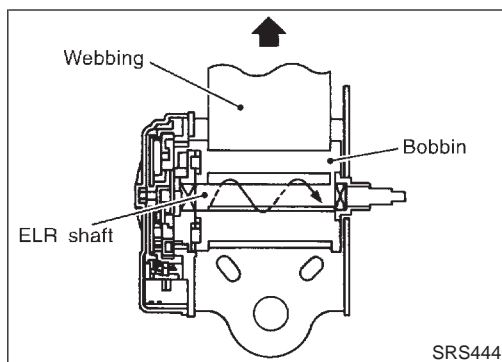

## Seat Belt Pre-tensioner with Load Limiter

=NFRS0034

The seat belt pre-tensioner system with load limiter is installed to both the driver's seat and the front passenger's seat. It operates simultaneously with the SRS air bag system in the event of a frontal collision with an impact exceeding a specified level.

When the frontal collision with an impact exceeding a specified level occurs, seat belt slack resulting from clothing or other factors is immediately taken up by the pre-tensioner. Vehicle passengers are securely restrained.

When passengers in a vehicle are thrown forward in a collision and the restraining force of the seat belt exceeds a specified level, the load limiter permits the specified extension of the seat belt by the twisting of the ELR shaft, and a relaxation of the chest-area seat belt web tension while maintaining force.

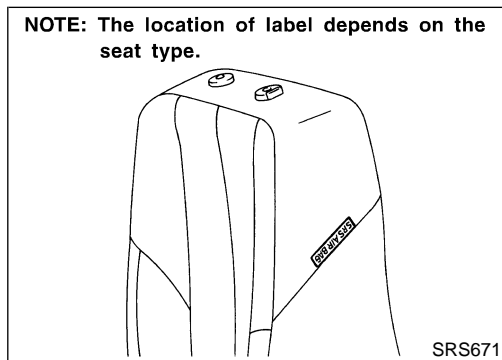

## Built-in Type Side Air Bag

NFRS0035

Front side air bag is built-in type.

The front seat backs with built-in type side air bag have the labels shown in figure at left.



# SUPPLEMENTAL RESTRAINT SYSTEM (SRS)

SRS Component Parts Location

## SRS Component Parts Location

NFRS0011

SRS configurations vary with vehicle depending on the optional equipment.  
SEC. 240•251•253•489•680•868•870

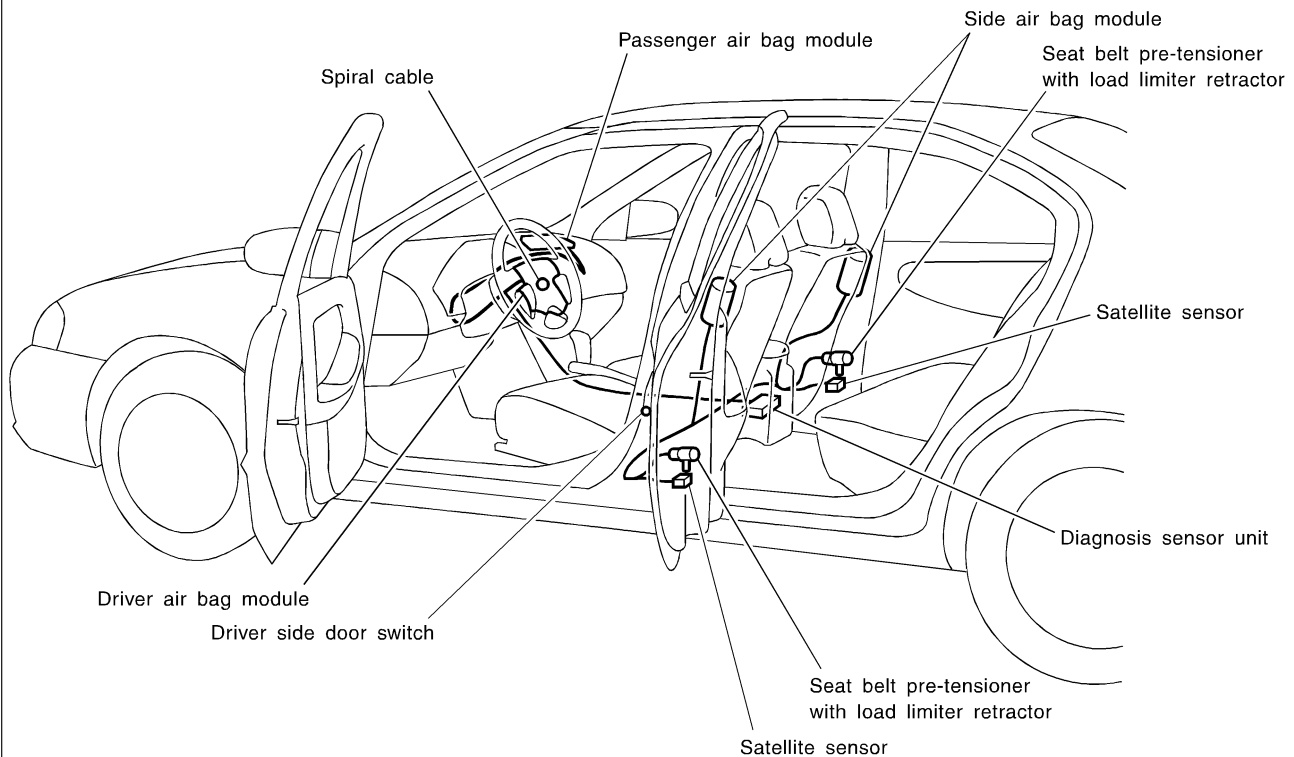

SRS672

GI

MA

EM

LC

EC

FE

CL

MT

AT

AX

SU

BR

ST

RS

BT

HA

SC

EL

IDX

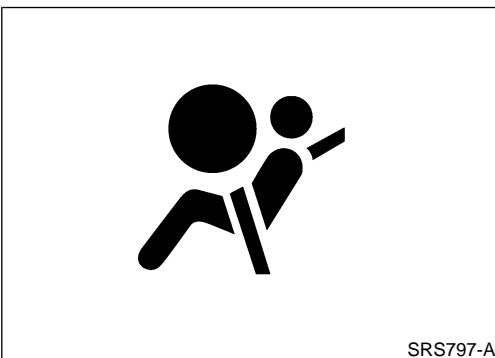

SRS797-A

## Maintenance Items

NFRS0012

### CAUTION:

Do not use electrical test equipment to check SRS circuit.

1. Check operation of "AIR BAG" warning lamp.  
After turning ignition key to "ON" position, "AIR BAG" warning lamp illuminates. The "AIR BAG" warning lamp will go off after about 7 seconds if no malfunction is detected. If any of the following "AIR BAG" warning lamp conditions occur, immediately check the air bag system. Refer to RS-41 for details.
  - The "AIR BAG" warning lamp does not illuminate when the ignition switch is turned "ON".
  - The "AIR BAG" warning lamp does not go off about 7 seconds after the ignition switch is turned "ON".
  - The "AIR BAG" warning lamp blinks after about 7 seconds after the ignition switch is turned "ON".
2. Visually check SRS components.
  - 1) Diagnosis sensor unit
    - Check diagnosis sensor unit and bracket for dents, cracks and deformities.
    - Check connectors for damage, and terminals for deformities.
  - 2) Air bag module and steering wheel
    - Remove air bag module from steering wheel, instrument panel

# SUPPLEMENTAL RESTRAINT SYSTEM (SRS)

Maintenance Items (Cont'd)

---

or seatback. Check harness cover and connectors for damage, terminals for deformities, and harness for binding.

- Install driver air bag module to steering wheel to check fit or alignment with the wheel.
  - Check steering wheel for excessive free play.
  - Install passenger air bag module to instrument panel to check fit or alignment with the instrument panel.
  - Install side air bag module to seatback to check fit and alignment with the seat.
- 3) Spiral cable
- Check spiral cable for dents, cracks, or deformities.
  - Check connectors and protective tape for damage.
  - Check steering wheel for noise, binding or heavy operation.
- 4) Main harness, body harness, side air bag module sub-harness
- Check connectors for poor connections, damage, and terminals for deformities.
  - Check harnesses for binding, chafing or cut.
- 5) Seat belt pre-tensioner
- Check harness cover and connectors for damage, terminals for deformities, and harness for binding.
  - Check belts for damage and anchors for loose mounting.
  - Check retractor for smooth operation.
  - Perform self-diagnosis for seat belt pre-tensioner using "AIR BAG" warning lamp or CONSULT-II. Refer to "SRS Operation Check" for details. (RS-41)
- 6) Satellite sensor
- Check satellite sensor (including bracket portion) for dents, cracks or deformities.
  - Check connectors for damage, and terminals for deformities.

**CAUTION:**

Replace previously used special bolts and ground bolt with new ones.

## Diagnosis Sensor Unit

### REMOVAL AND INSTALLATION

NFRS0013

**CAUTION:**

- Before servicing SRS, turn the ignition switch off, disconnect both battery cables and wait at least 3 minutes.
- The special bolts are coated with bonding agent while the other bolt is for ground. Do not use old bolts after removal; replace with new ones.
- Check diagnosis sensor unit for proper installation.
- Check diagnosis sensor unit to ensure it is free of deformities, dents, cracks or rust. If they show any visible signs of damage, replace them with new ones.
- Check diagnosis sensor unit brackets to ensure they are free of deformities or rust.
- Replace diagnosis sensor unit if it has been dropped or sustained an impact.
- After replacement of diagnosis sensor unit, perform self-diagnosis for SRS. Refer to "SRS Operation Check" for details. (RS-41)

# SUPPLEMENTAL RESTRAINT SYSTEM (SRS)

Diagnosis Sensor Unit (Cont'd)

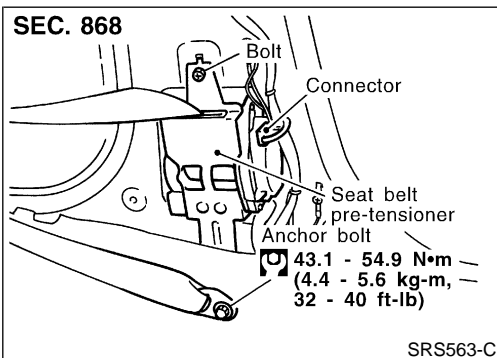
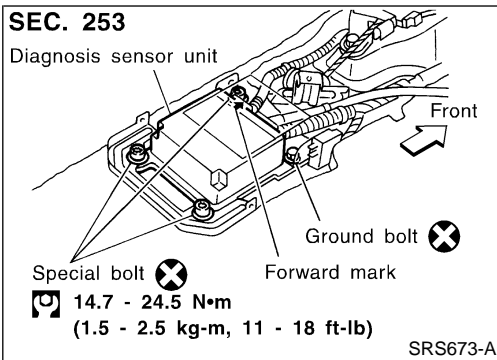

1. Disconnect driver, passenger and side air bag module connectors. Also, disconnect seat belt pre-tensioner connector.
2. Remove console box. Refer to BT-28, "INSTRUMENT PANEL ASSEMBLY".
3. Disconnect diagnosis sensor unit connector.
4. Remove ground bolt and also remove special bolts using the TAMPER RESISTANT TORX (Size T50), from diagnosis sensor unit.  
Then remove the diagnosis sensor unit.

## NOTE:

- To install, reverse the removal procedure sequence.

## Seat Belt Pre-tensioner

### REMOVAL AND INSTALLATION

NFRS0036

#### CAUTION:

- Before servicing SRS, turn the ignition switch off, disconnect both battery cables and wait at least 3 minutes.
- Check seat belt pre-tensioner with load limiter for proper installation.
- After replacement of seat belt pre-tensioner, check SRS function and perform self-diagnosis for SRS. Refer to "SRS Operation Check" for details. (RS-41)
- Do not attempt to disassemble seat belt pre-tensioner with load limiter.
- Replace seat belt pre-tensioner if it has been dropped or sustained an impact.
- Do not expose seat belt pre-tensioner to temperatures exceeding 80°C (176°F).

For removal of seat belt pre-tensioner, refer to "Front Seat Belt" for details. (RS-5)

## NOTE:

- To install, reverse the removal procedure sequence.

## Satellite Sensor

### REMOVAL AND INSTALLATION

NFRS0014

#### CAUTION:

- Before servicing SRS, turn the ignition switch off, disconnect both battery cables and wait at least 3 minutes.
- Do not use old bolts coated with bonding agent after removal; replace with new ones.
- Check satellite sensor for proper installation.
- Check satellite sensor to ensure they are free of deformities, dents, cracks or rust. If it shows any visible signs of damage, replace it with new one.
- After replacement of satellite sensor, check SRS function and perform self-diagnosis for SRS. Refer to "SRS Operation Check" for details. (RS-41)
- Do not attempt to disassemble satellite sensor.
- Replace satellite sensor if it has been dropped or sustained an impact.

GI  
MA  
EM  
LC  
EC  
FE  
CL  
MT  
AT  
AX  
SU  
BR  
ST  
RS  
BT  
HA  
SC  
EL  
IDX

# SUPPLEMENTAL RESTRAINT SYSTEM (SRS)

Satellite Sensor (Cont'd)

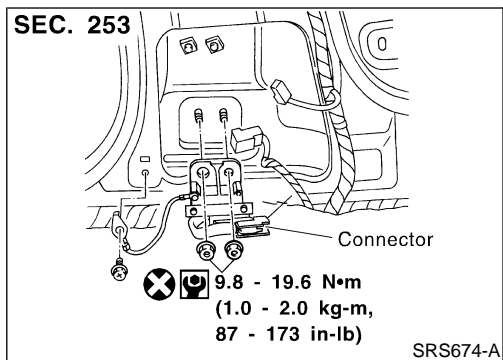

1. Remove seat belt pre-tensioner. Refer to "Front Seat Belt" for details. (RS-5)
2. Disconnect satellite sensor connector.
3. Remove bolt and nuts from satellite sensor unit. Then remove the satellite sensor.

**NOTE:**

- To install, reverse the removal procedure sequence.

## Driver Air Bag Module and Spiral Cable

### REMOVAL AND INSTALLATION

NFRS0015

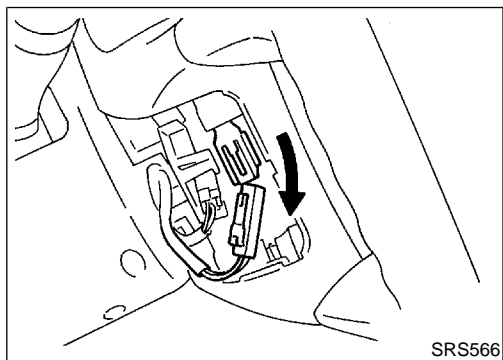
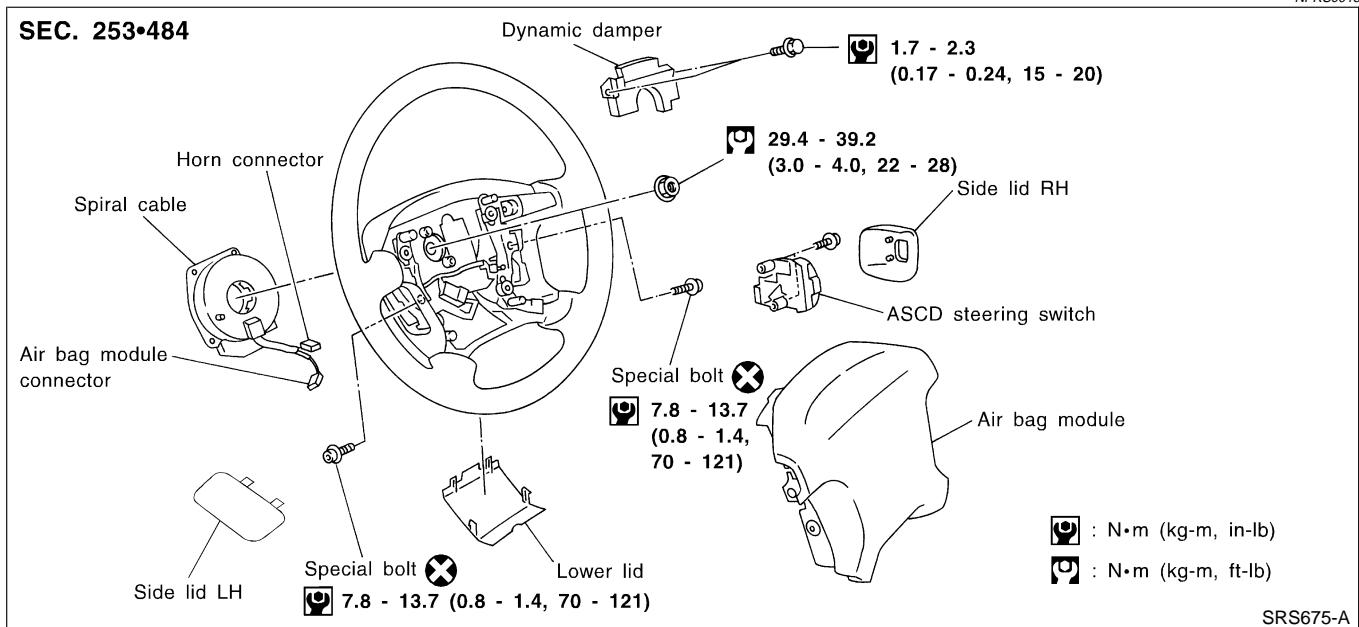

### REMOVAL

NFRS0016

**CAUTION:**

- Before servicing SRS, turn the ignition switch off, disconnect both battery cables and wait at least 3 minutes.
- Always work from the side of air bag module.

1. Remove lower lid from steering wheel, and disconnect air bag module connector.

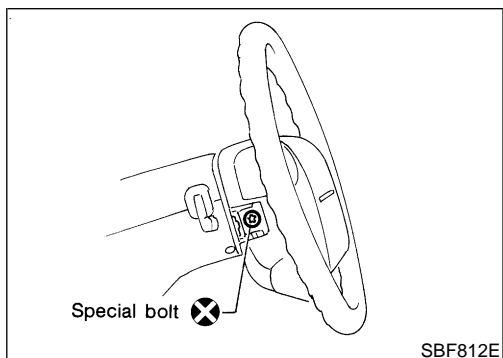

2. Remove side lids, ASCD steering switch. Using the TAMPER RESISTANT TORX (Size T30), remove left and right special bolts. Air bag module can then be removed.

# SUPPLEMENTAL RESTRAINT SYSTEM (SRS)

Driver Air Bag Module and Spiral Cable (Cont'd)

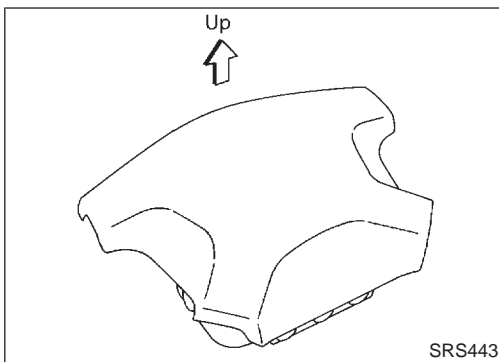

## CAUTION:

- Always place air bag module with pad side facing upward.
- Do not attempt to disassemble air bag module.
- The special bolts are coated with bonding agent. Do not use old bolts after removal; replace with new ones.
- Do not insert any foreign objects (screwdriver, etc.) into air bag module connector.

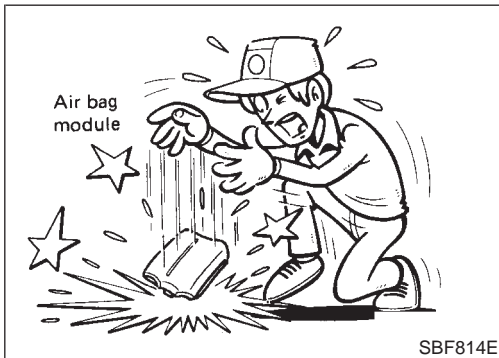

- Replace air bag module if it has been dropped or sustained an impact.
- Do not expose the air bag module to temperatures exceeding 90°C (194°F).
- Do not allow oil, grease or water to come in contact with the air bag module.

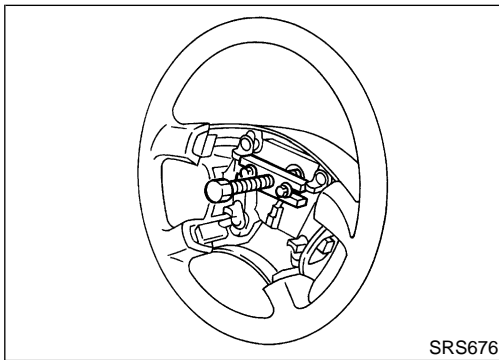

3. Set steering wheel in the neutral position.
4. Disconnect horn connector and remove nuts.
5. Remove dynamic damper. Then using steering wheel puller, remove steering wheel. Be careful not to over-tighten puller bolt on steering wheel.

## CAUTION:

- Do not tap or bump the steering wheel.
6. Remove steering column cover.

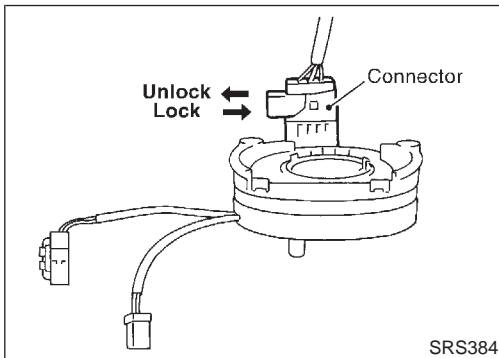

7. Remove four spiral cable securing screws, and extract spiral cable forward. Unlock spiral cable connector, then remove spiral cable.

## CAUTION:

- Do not attempt to disassemble spiral cable.
- Do not apply lubricant to the spiral cable.

GI  
MA  
EM  
LC  
EC  
FE  
CL  
MT  
AT  
AX  
SU  
BR  
ST  
RS  
BT  
HA  
SC  
EL  
IDX

# SUPPLEMENTAL RESTRAINT SYSTEM (SRS)

Driver Air Bag Module and Spiral Cable (Cont'd)

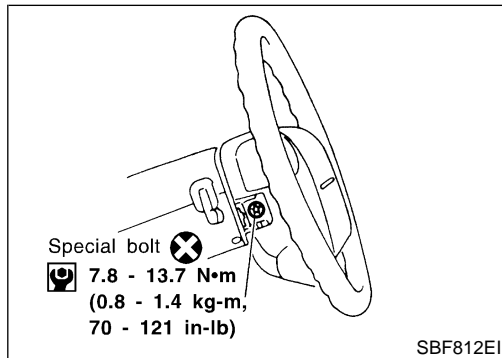
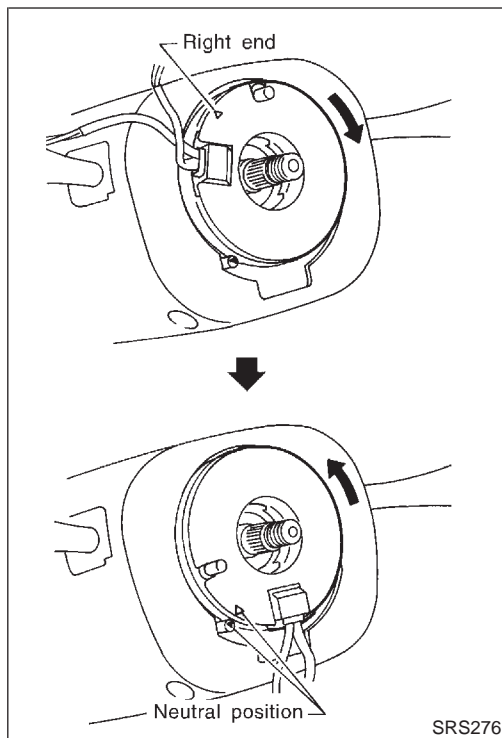

## INSTALLATION

NFRS0017

1. Set the front wheels in the straight-ahead position.
2. Make sure that the spiral cable is in the neutral position. The neutral position is detected by turning left about 2.5 revolutions from the right end position. Align the two marks (X).

### CAUTION:

- The spiral cable may snap due to steering operation if the cable is installed in an improper position.
- Also, with the steering linkage disconnected, the cable may snap by turning the steering wheel beyond the limited number of turns. The spiral cable can be turned to the left about 2.5 turns from the right end position.

3. Connect spiral cable connector and tighten with screws. Install steering column cover.
4. Install steering wheel, aligning with spiral cable pin guides, and pull spiral cable through.
5. Connect horn connector and engage spiral cable with pawls in steering wheel. Move air bag module connector away from steering wheel lower lid opening.
6. Tighten nut.  
⚙️ : 29.4 - 39.2 N·m (3.0 - 4.0 kg-m, 22 - 29 ft-lb)
7. Install dynamic damper.

8. Position air bag module and tighten with new special bolts.
9. Connect air bag module connector.
10. Install steering switch and lids.
11. Conduct self-diagnosis to ensure entire SRS operates properly. (Use CONSULT-II or warning lamp check.) Before performing self-diagnosis, connect both battery cables.
12. Turn steering wheel to the left end and then to the right end fully to make sure that spiral cable is set in the neutral position.

If "AIR BAG" warning lamp blinks or stays ON (at the user mode), it shows the spiral cable may be snapped due to its improper position. Perform self-diagnosis again (use CONSULT-II or warning lamp). If a malfunction is detected, replace the spiral cable with a new one.

13. Perform self-diagnosis again to check that no malfunction is detected.

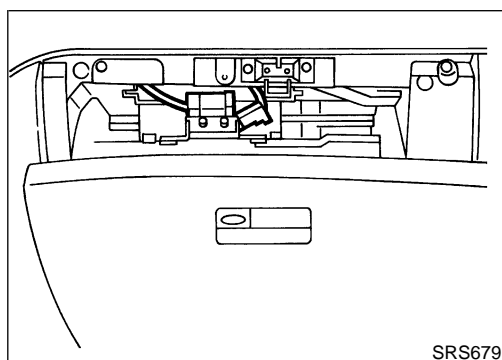

## Front Passenger Air Bag Module

### REMOVAL

NFRS0018

### CAUTION:

- Before servicing SRS, turn the ignition switch off, disconnect both battery cables and wait for at least 3 minutes.
  - Always work from the side of or under air bag module.
1. Open the glove box lid.
  2. Open the connector cover.
  3. Disconnect front passenger air bag module connector from air bag harness connector.

# SUPPLEMENTAL RESTRAINT SYSTEM (SRS)

Front Passenger Air Bag Module (Cont'd)

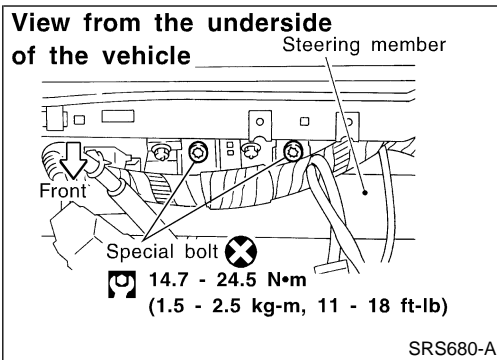

4. Remove glove box assembly. Refer to BT-28, "INSTRUMENT PANEL ASSEMBLY" for details.
5. Remove the special bolts using the TAMPER RESISTANT TORX (Size T50) from front passenger air bag module. Take out the air bag module from the instrument panel.
  - The air bag module is heavy and should be supported using both hands during removal.

GI  
MA  
EM  
LC

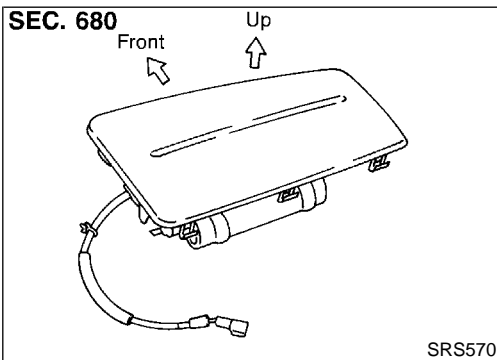

**CAUTION:**

- Always place air bag module with pad side facing upward.
- Do not attempt to disassemble air bag module.
- The special bolts are coated with bonding agent. Do not use old bolts after removal; replace with new coated bolts.
- Do not insert any foreign objects (screwdriver, etc.) into air bag module connector.

EC  
FE  
CL  
MT

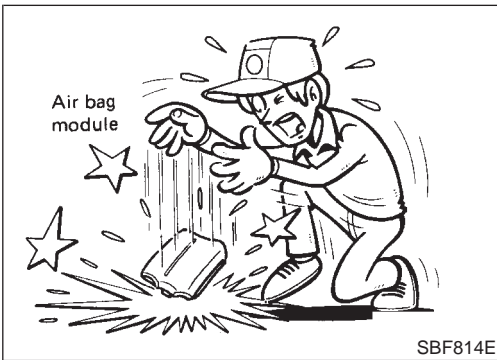

- Replace air bag module if it has been dropped or sustained an impact.
- Do not expose the air bag module to temperatures exceeding 90°C (194°F).
- Do not allow oil, grease or water to come in contact with the air bag module.
- After air bag inflates, the front instrument panel assembly should be replaced if damaged.

AT  
AX  
SU  
BR

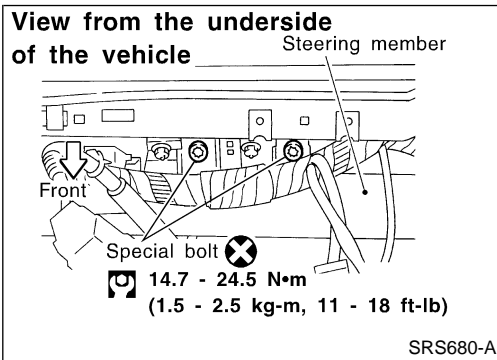

**INSTALLATION**

NFRS0019

**CAUTION:**

- Always work from the side of or under air bag module.
1. Install front passenger air bag module on steering member.
  - Ensure harness is not caught between rear of air bag module and steering member.
  2. Install glove box assembly. (Glove box lid is open.)

ST

**RS**

BT

HA

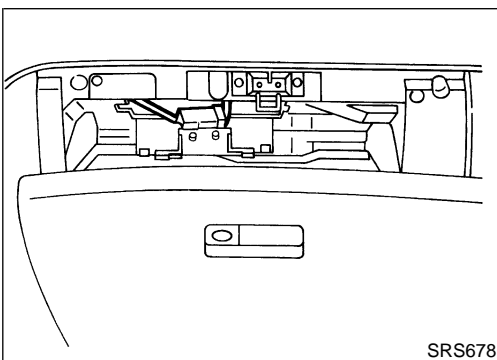

3. Connect air bag module connector to air bag harness connector.
4. Close the connector cover.
5. Close the glove box lid.
6. Connect both battery cable.
7. Conduct self-diagnosis to ensure entire SRS operates properly. (Use CONSULT-II or warning lamp check.)

SC

EL

IDX

# SUPPLEMENTAL RESTRAINT SYSTEM (SRS)

## Side Air Bag Module

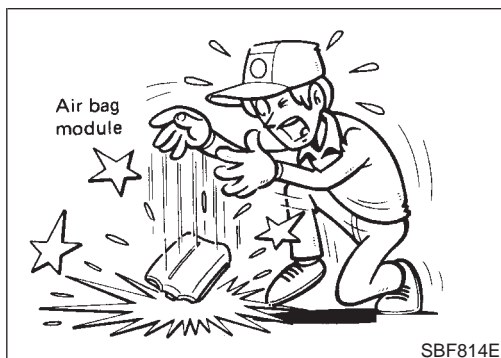
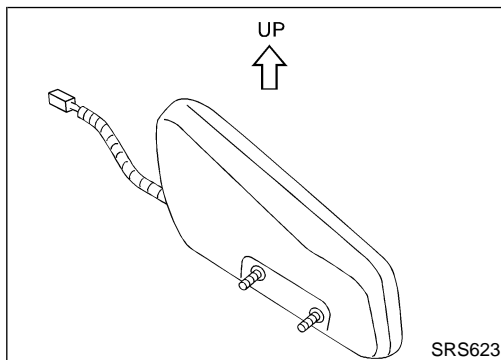
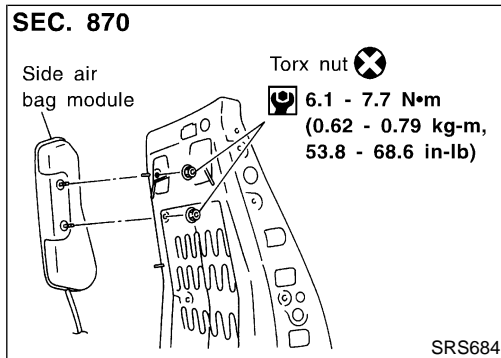
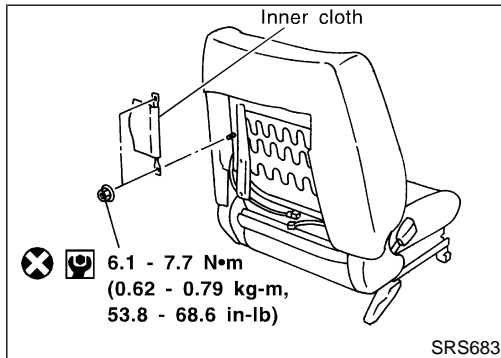
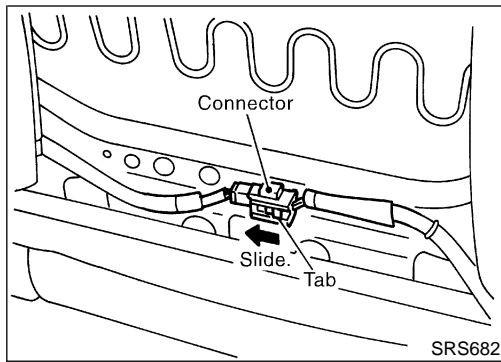

## Side Air Bag Module

### REMOVAL

NFRS0020

#### CAUTION:

- Before servicing SRS, turn the ignition switch OFF, disconnect both battery cables and wait at least 3 minutes.
  - Always work from the rear of the air bag module.
1. Remove seat back board.
  - When using a clip removal tool to remove the seat back board, take care not to damage the harness for air bag.
  2. Disconnect side air bag module connector by sliding tab.
  3. Pull up the seat back trim.
  4. Remove the nuts securing the inner cloth with seat back frame. Then pull up the inner cloth.
  5. Remove the seat back trim. Refer to BT-46, "Front Seat" for detail.
  6. Remove the torx nuts coated with bonding agent from the side air bag module.
  7. Remove side air bag connector. Side air bag module can then be removed.

#### CAUTION:

- Always place the air bag module standing with the stud bolt side setting bottom.
  - Do not attempt to disassemble air bag module.
  - The torx nuts are coated with bonding agent. Do not use old nuts after removal; replace with new coated nuts.
  - Do not insert any foreign objects (screwdriver, etc.) into air bag module connector.
- Replace air bag module if it has been dropped or sustained an impact.
  - Do not expose the air bag module to temperatures exceeding  $90^{\circ}\text{C}$  ( $194^{\circ}\text{F}$ ).
  - Do not allow oil, grease or water to come in contact with the air bag module.
  - After air bag inflates, all parts of front seat back (including front seat back frame) should be replaced.



# SUPPLEMENTAL RESTRAINT SYSTEM (SRS)

Side Air Bag Module (Cont'd)

## SEC. 870

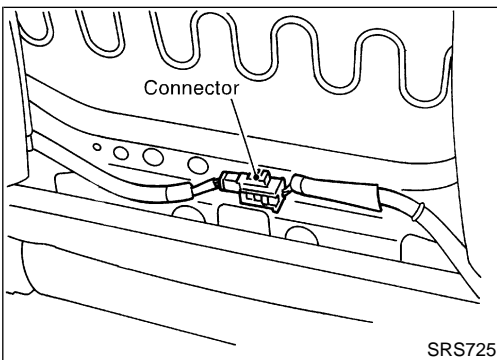
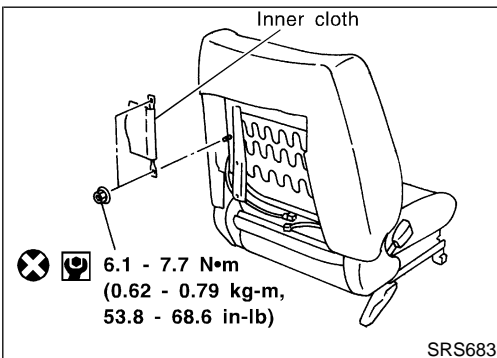
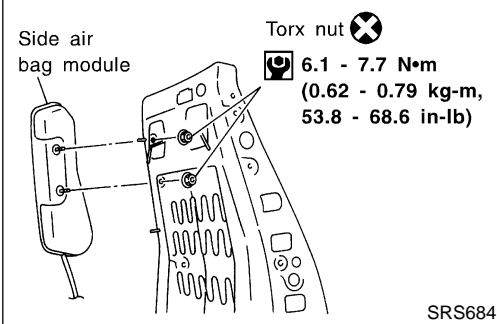

## INSTALLATION

NFRS0021

1. Install side air bag module on seat back frame with new torx nuts coated with bonding agent.
2. Install side air bag connector.
3. Install the seat back trim. Refer to BT-46, "Front Seat".
4. Secure the inner cloth which covers the side air bag module with nuts.
5. Connect side air bag module connector.
6. Install seat back board with new clips.
7. Connect both battery cables.
8. Go to "SRS Operation Check", RS-41 and perform self-diagnosis to ensure entire SRS operates properly. (Use CONSULT-II or air bag warning lamp.)

GI

MA

EM

LC

EC

FE

CL

MT

AT

AX

SU

BR

ST

RS

BT

HA

SC

EL

IDX

## Disposal of Air Bag Module and Seat Belt Pre-tensioner

NFRS0022

- Before disposing of air bag module and seat belt pre-tensioner, or vehicles equipped with such systems, deploy the systems. If such systems have already been deployed due to an accident, dispose of them as indicated in "DISPOSING OF AIR BAG MODULE AND SEAT BELT PRE-TENSIONER" (RS-30).
- When deploying the air bag module and seat belt pre-tensioner, always use the Special Service Tool; Deployment tool KV99106400 (J38381).
- When deploying the air bag module and seat belt pre-tensioner, stand at least 5 m (16 ft) away from the deployment component.
- When deploying air bag module and seat belt pre-tensioner, a fairly loud noise is made, followed by smoke being released. The smoke is not poisonous, however, be careful not to inhale smoke since it irritates the throat and can cause choking.
- Always activate one air bag module at a time.
- Due to heat, leave air bag module unattended for more than 30 minutes after deployment. Also leave seat belt pre-tensioner unattended for more than 10 minutes after deployment.
- Be sure to wear gloves when handling a deployed air bag

# SUPPLEMENTAL RESTRAINT SYSTEM (SRS)

Disposal of Air Bag Module and Seat Belt Pre-tensioner (Cont'd)

module and seat belt pre-tensioner.

- Never apply water to the deployed air bag module and seat belt pre-tensioner.
- Wash your hands clean after finishing work.
- Place the vehicle outdoors with an open space of at least 6 m (20 ft) on all sides when deploying air bag module and seat belt pre-tensioner while mounted in vehicle.
- Use a voltmeter to make sure the vehicle battery is fully charged.
- Do not dispose of the air bag module and seat belt pre-tensioner un-deployed.

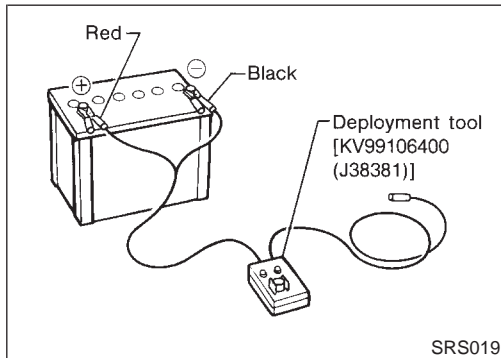

## CHECKING DEPLOYMENT TOOL

### Connecting to Battery

NFRS0022S01

NFRS0022S0101

#### CAUTION:

**The battery must show voltage of 9.6V or more.**

Remove the battery from the vehicle and place it on dry wood blocks approximately 5 m (16 ft) away from the vehicle.

- Wait 3 minutes after the vehicle battery is disconnected before proceeding.
- Connect red clip of deployment tool to battery positive terminal and black clip to negative terminal.

**Make sure the polarity is correct. The right side lamp in the tool, marked "deployment tool power", should glow with a green light. If the right side lamp glows red, reverse the connections to the battery.**

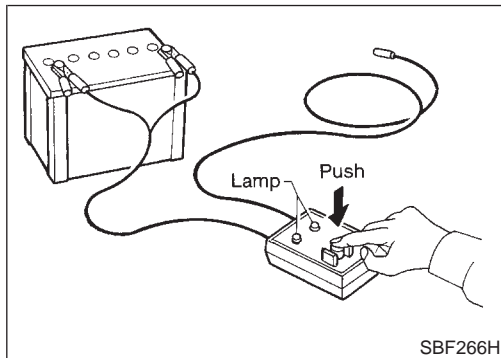

### Deployment Tool Check

NFRS0022S0102

Press the deployment tool switch to the "ON" position. The left side lamp in the tool, marked "air bag connector voltage" should illuminate. If it does not illuminate, replace the tool.

### Air Bag Deployment Tool Lamp Illumination Chart (Battery connected)

NFRS0022S0103

Switch operation	Left side lamp, green* "AIR BAG CONNECTOR VOLTAGE"	Right side lamp, green* "DEPLOYMENT TOOL POWER"
OFF	OFF	ON
ON	ON	ON

\*: If this lamp glows red, the tool is connected to the battery incorrectly. Reverse the connections and make sure the lamp glows green.

# SUPPLEMENTAL RESTRAINT SYSTEM (SRS)

Disposal of Air Bag Module and Seat Belt Pre-tensioner (Cont'd)

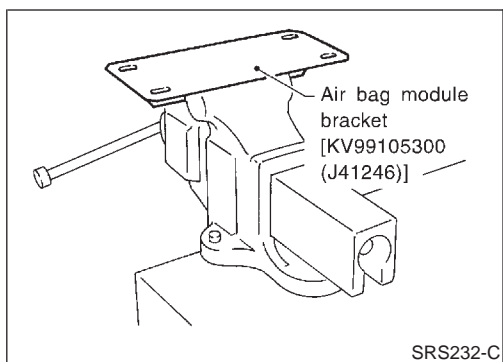

## DEPLOYMENT PROCEDURES FOR AIR BAG MODULE (OUTSIDE OF VEHICLE)

NFRS0022S02

Unless the vehicle is being scrapped, deploying the air bag in the vehicle interior.

Anchor air bag module bracket [KV99105300 (J41246)] in a vise secured to a firm foundation during deployment.

### Deployment of Driver's Air Bag Module (Outside of vehicle)

NFRS0022S0201

1. Using wire, secure air bag module to air bag module bracket [SST: KV99105300 (J41246)] at two places.

#### CAUTION:

Use wire of at least 1 mm (0.04 in) diameter.

2. Firmly secure air bag module bracket [SST: KV99105300 (J41246)] with air bag module attached, in a vise.

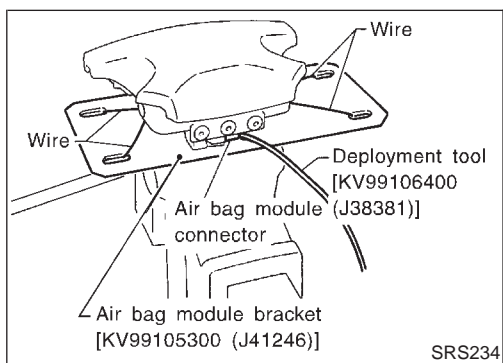
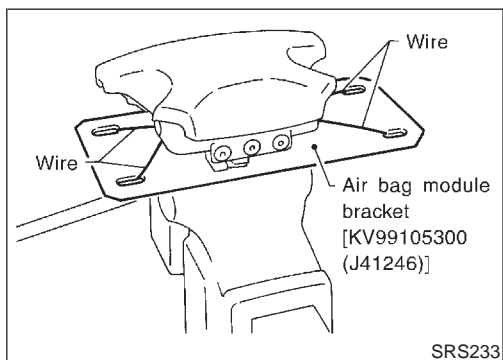

3. Connect deployment tool [SST: KV99106400 (J38381)] to air bag module connector.

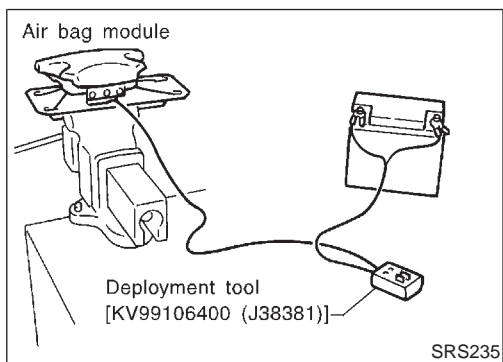

4. Connect red clip of deployment tool to battery positive terminal and black clip to negative terminal.
5. The lamp on the right side of the tool, marked "deployment tool power", should glow green, not red.
6. Press the button on the deployment tool. The left side lamp on the tool, marked "air bag connector voltage", will illuminate and the air bag module will deploy.

#### CAUTION:

When deploying the air bag module, stand at least 5 m (16 ft) away from the air bag module.

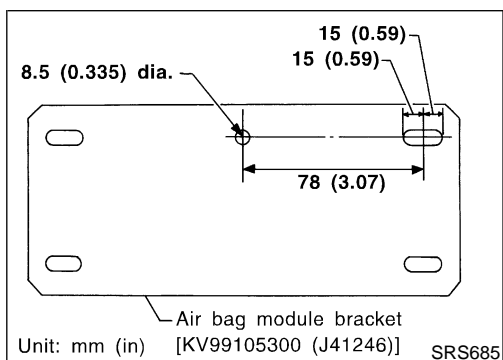

### Deployment of Passenger Air Bag Module (Outside of vehicle)

NFRS0022S0202

1. Make an 8.5 mm (0.335 in) diameter hole in air bag module bracket [SST: KV99105300 (J41246)] at the position shown in figure at left.

GI

MA

EM

LC

EC

FE

CL

MT

AT

AX

SU

BR

ST

RS

BT

HA

SC

EL

IDX

# SUPPLEMENTAL RESTRAINT SYSTEM (SRS)

Disposal of Air Bag Module and Seat Belt Pre-tensioner (Cont'd)

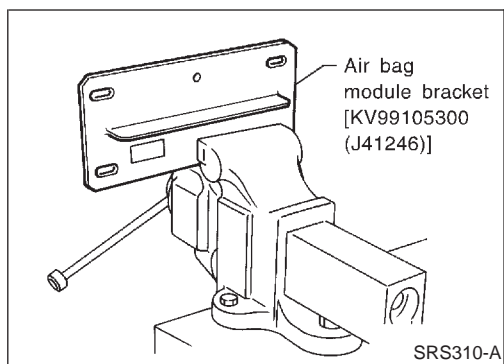

2. Firmly secure air bag module bracket [SST: KV99105300 (J41246)] in a vise.

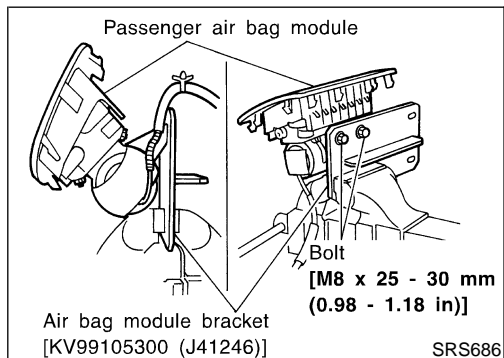

3. Match the two holes in air bag module bracket (held in vise) and passenger air bag module and fix them with two bolts [M8 x 25 - 30 mm (0.98 - 1.18 in)].

**CAUTION:**

If a gap exists between passenger air bag module and air bag module bracket, use a piece of wood inserted in the gap to stabilize the air bag module.

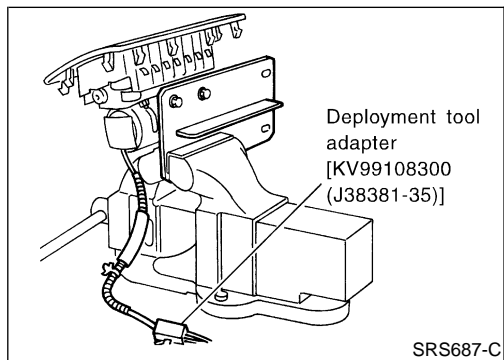

4. Connect deployment tool adapter [SST: KV99108300 (J38381-35)] to deployment tool [SST: KV99106400 (J38381)] connector and air bag module connector.
5. Connect red clip of deployment tool to battery positive terminal and black clip to negative terminal.
6. The lamp on the right side of the tool, marked "deployment tool power", should glow green, not red.
7. Press the button on the deployment tool. The left side lamp on the tool, marked "air bag connector voltage", will illuminate and the air bag module will deploy.

**CAUTION:**

- When deploying the air bag module, do not stand on the deploying side.
- Stand at least 5 m (16 ft) away from the air bag module.

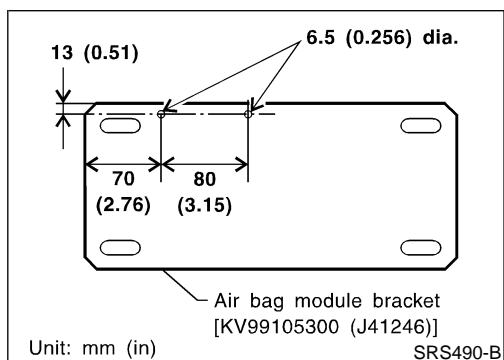
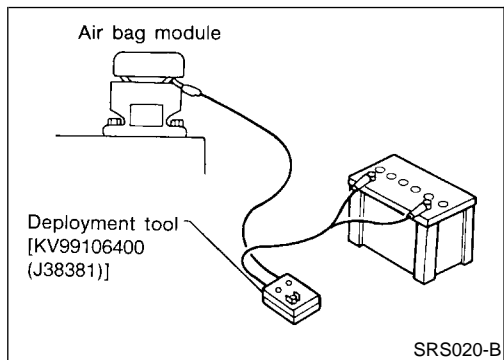

## Deployment of Side Air Bag Module (Built-in type) (Outside of vehicle)

NFRS0022S0203

1. Make 6.5 mm (0.256 in) diameter holes in air bag module bracket [SST: KV99105300 (J41246)] at the position shown in figure at left.

# SUPPLEMENTAL RESTRAINT SYSTEM (SRS)

Disposal of Air Bag Module and Seat Belt Pre-tensioner (Cont'd)

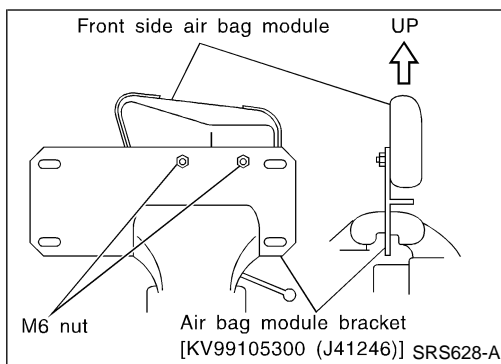

2. Firmly secure air bag module bracket [SST: KV99105300 (J41246)] in a vise.
3. Insert the stud bolts of side air bag module into the two holes in air bag module bracket (held in vise) and fix them with two M6 nuts.

**CAUTION:**

Side air bag module should be secured to air bag module bracket [SST: KV99105300 (J41246)] in a vise with stud bolt side setting bottom.

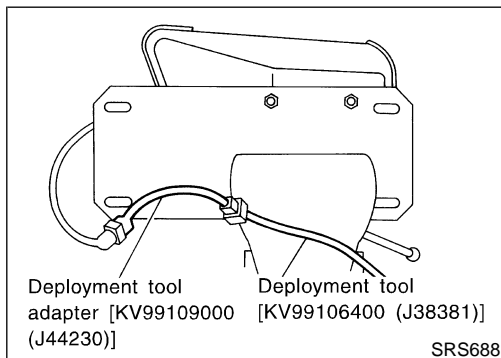

4. Connect deployment tool adapter [SST: KV99109000 (J44230)] to deployment tool [SST: KV99106400 (J38381)] connector and connector on air bag module.

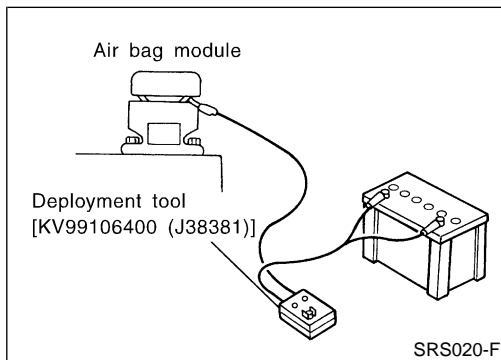

5. Connect red clip of deployment tool to battery positive terminal and black clip to negative terminal.
6. The lamp on the right side of the tool, marked "deployment tool power", should glow green, not red.
7. Press the button on the deployment tool. The left side lamp on the tool, marked "air bag connector voltage", will illuminate and the air bag module will deploy.

**CAUTION:**

When deploying the air bag module, stand at least 5 m (16 ft) away from the air bag module.

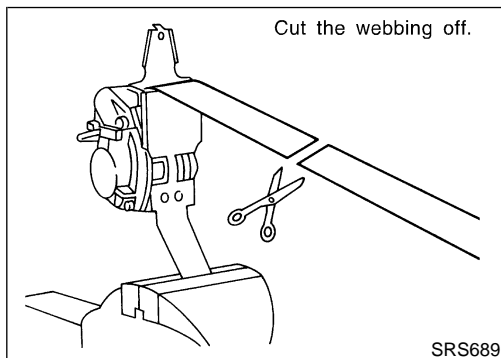

## DEPLOYMENT PROCEDURES FOR SEAT BELT PRE-TENSIONER (OUTSIDE OF VEHICLE)

NFRS0022S05

1. Firmly grip pre-tensioner in a vise and cut the webbing off.

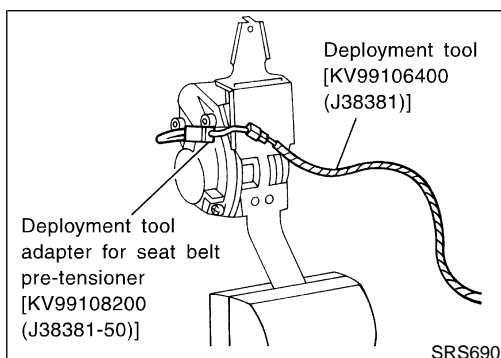

2. Connect deployment tool adapter [SST: KV99108200 (J38381-50)] to deployment tool [SST: KV99106400 (J38381)] connector and seat belt pre-tensioner connector.

GI  
MA  
EM  
LC  
EC  
FE  
CL  
MT  
AT  
AX  
SU  
BR  
ST  
RS  
BT  
HA  
SC  
EL  
IDX

# SUPPLEMENTAL RESTRAINT SYSTEM (SRS)

## Disposal of Air Bag Module and Seat Belt Pre-tensioner (Cont'd)

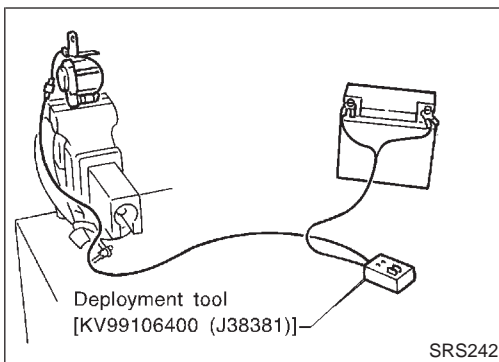

3. Connect red clip of deployment tool to battery positive terminal and black clip to negative terminal.
4. The lamp on the right side of the tool, marked "deployment tool power", should glow green, not red.
5. Press the button on the deployment tool. The left side lamp on the tool, marked "seat belt pre-tensioner connector voltage", will illuminate and the seat belt pre-tensioner will deploy.

### CAUTION:

**When deploying the seat belt pre-tensioner, stand at least 5 m (16 ft) away from the seat belt pre-tensioner.**

## DEPLOYMENT OF AIR BAG MODULE AND SEAT BELT PRE-TENSIONER WHILE MOUNTED IN VEHICLE

NFRS0022S03

When disposing of a vehicle, deploy air bag module and seat belt pre-tensioners while they are mounted in vehicle.

### CAUTION:

**When deploying air bag module or seat belt pre-tensioner, ensure vehicle is empty.**

1. Disconnect both the vehicle battery cables and wait 3 minutes.
2. Disconnect air bag module and seat belt pre-tensioner connector.
3. Connect deployment tool [SST: KV99106400 (J38381)] to air bag module or seat belt pre-tensioner.  
For front passenger air bag module, attach deployment tool adapter [SST: KV99108300 (J38381-35)] to the tool connector.  
For side air bag module (built-in type), attach deployment tool adapter [SST: KV9910900 (J44230)]. For seat belt pre-tensioner, attach deployment tool adapter [SST: KV99108200 (J38381-50)] to the tool connector.

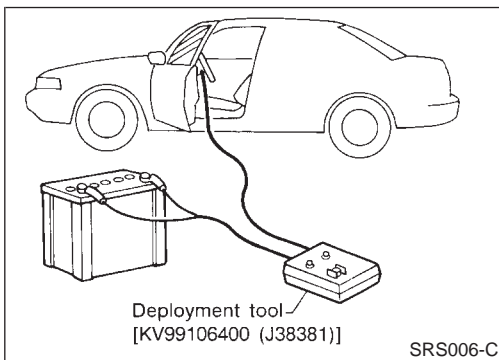

4. Connect red clip of deployment tool to battery positive terminal and black clip to negative terminal.
5. The lamp on the right side of the tool, marked "deployment tool power", should glow green, not red.
6. Press the button on the deployment tool. The left side lamp on the tool, marked "air bag connector voltage", will illuminate and the air bag module or seat belt pre-tensioner will deploy.

### CAUTION:

**Activate only one air bag module or seat belt pre-tensioner at a time.**

## DISPOSING OF AIR BAG MODULE AND SEAT BELT PRE-TENSIONER

NFRS0022S04

Deployed air bag module and seat belt pre-tensioner are very hot. Before disposing of air bag module, and seat belt pre-tensioner wait at least 30 minutes, and 10 minutes, respectively. Seal them in a plastic bag before disposal.

### CAUTION:

- Never apply water to a deployed air bag module and seat belt pre-tensioner.
- Be sure to wear gloves when handling a deployed air bag module and seat belt pre-tensioner.

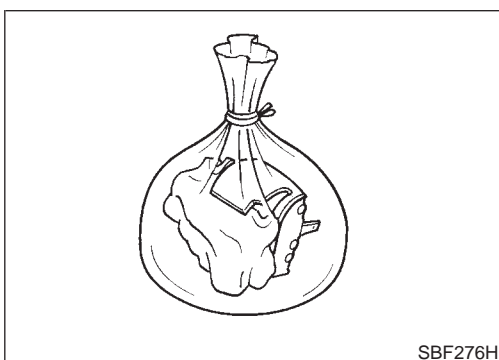

# SUPPLEMENTAL RESTRAINT SYSTEM (SRS)

*Disposal of Air Bag Module and Seat Belt Pre-tensioner (Cont'd)*

- No poisonous gas is produced upon air bag module deployment. However, be careful not to inhale gas since it irritates throat and can cause choking.
- Do not attempt to disassemble air bag module and seat belt pre-tensioner.
- Air bag module and seat belt pre-tensioner cannot be reused.
- Wash your hands clean after finishing work.

GI

MA

EM

LC

EC

FE

CL

MT

AT

AX

SU

BR

ST

**RS**

BT

HA

SC

EL

IDX

# SUPPLEMENTAL RESTRAINT SYSTEM (SRS)

Trouble Diagnoses Introduction

## Trouble Diagnoses Introduction

=NFRS0043

### CAUTION:

- Do not use electrical test equipment on any circuit related to the SRS unless instructed to in this Service Manual. Spiral cable and wiring harnesses covered with yellow insulation tape either just before the harness connectors or for the complete harness are related to the SRS.
- Do not attempt to repair, splice or modify the SRS wiring harness. If the harness is damaged, replace it with a new one.
- Keep ground portion clean.

### DIAGNOSIS FUNCTION

The SRS self-diagnosis results can be read by using “AIR BAG” warning lamp and/or CONSULT-II. The reading of these results is accomplished using one of two modes — “User mode” and “Diagnosis mode”. NFRS0043S01

The User mode is exclusively prepared for the customer (driver). This mode warns the driver of a system malfunction through the operation of the “AIR BAG” warning lamp.

The Diagnosis mode allows the technician to locate and inspect the malfunctioning part. The mode applications for the “AIR BAG” warning lamp and CONSULT-II are as follows:

	User mode	Diagnosis mode	Display type
“AIR BAG” warning lamp	X	X	ON-OFF operation
CONSULT-II	—	X	Monitoring

### NOTE:

Seat belt pre-tensioner malfunction is indicated by “AIR BAG” warning lamp.

### DIAGNOSIS MODE FOR CONSULT-II

NFRS0043S02

- “SELF-DIAG [CURRENT]”  
A current Self-diagnosis result (also indicated by the number of warning lamp flashes in the Diagnosis mode) is displayed on the CONSULT-II screen in real time. This refers to a malfunctioning part requiring repairs.
- “SELF-DIAG [PAST]”  
Diagnosis results previously stored in the memory are displayed on the CONSULT-II screen. The stored results are not erased until memory erasing is executed.
- “TROUBLE DIAG RECORD”  
With TROUBLE DIAG RECORD, diagnosis results previously erased by a reset operation can be displayed on the CONSULT-II screen.
- “ECU DISCRIMINATED NO.”  
The diagnosis sensor unit for each vehicle model is assigned with its own, individual classification number. This number will be displayed on the CONSULT-II screen, as shown below. When replacing the diagnosis sensor unit, refer to the part number for the compatibility. After installation, replacement with a correct unit can be checked by confirming this classification number on the CONSULT-II screen.

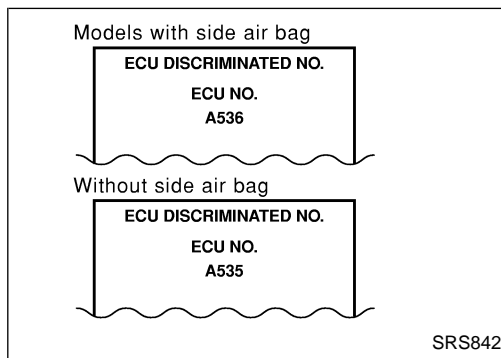

For NISSAN MODEL A33, the diagnosis sensor unit classification numbers assigned are A536 (with side air bag) and A535 (without side air bag).



# SUPPLEMENTAL RESTRAINT SYSTEM (SRS)

Trouble Diagnoses Introduction (Cont'd)

## ④ HOW TO CHANGE SELF-DIAGNOSIS MODE WITH CONSULT-II

=NFRS0043S03

### From User Mode to Diagnosis Mode

NFRS0043S0301

After selecting "AIR BAG" on the "SELECT SYSTEM" screen, User mode automatically changes to Diagnosis mode.

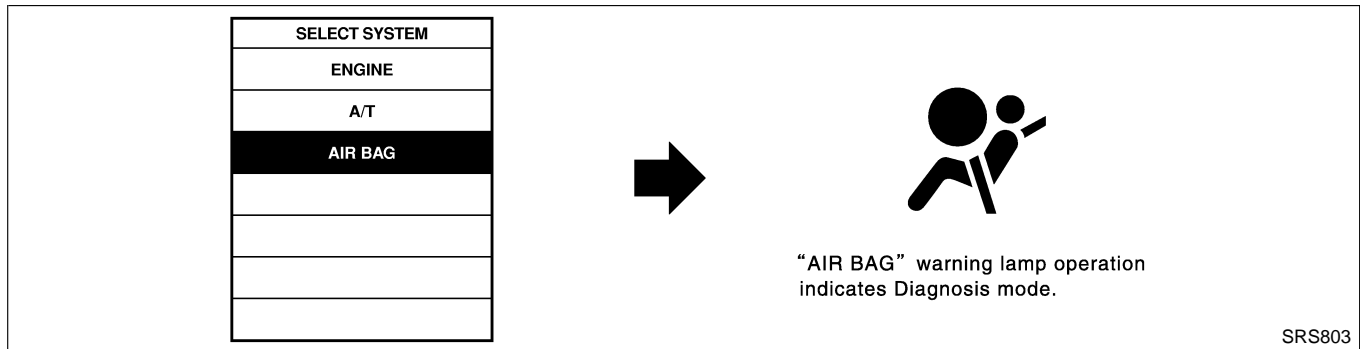

### From Diagnosis Mode to User Mode

NFRS0043S0302

To return to User mode from Diagnosis mode, touch "BACK" key of CONSULT-II until "SELECT SYSTEM" appears, Diagnosis mode automatically changes to User mode.

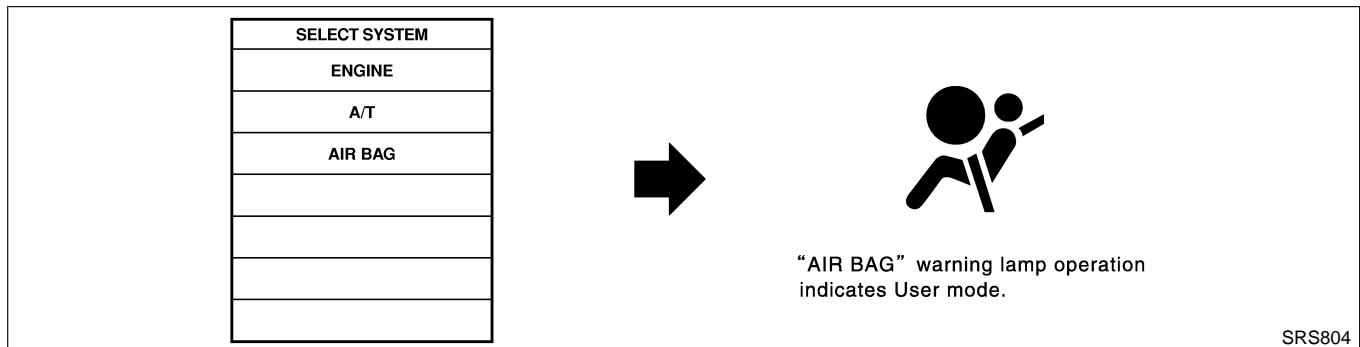

## ⊗ HOW TO CHANGE SELF-DIAGNOSIS MODE WITHOUT CONSULT-II

NFRS0043S04

### From User Mode to Diagnosis Mode

NFRS0043S0401

Diagnosis mode activates only when a malfunction is detected, by turning ignition switch as follows:

- 1) Turn ignition switch "ON".
- 2) After "AIR BAG" warning lamp lights for 7 seconds, turn ignition switch "OFF" within 1 second.
- 3) Wait more than 3 seconds.
- 4) Repeat steps 1 to 3 three times.
- 5) Turn ignition switch "ON".

SRS will not enter Diagnosis mode, if no malfunction is detected.

### From Diagnosis Mode to User Mode

NFRS0043S0402

After a malfunction is repaired, switch the ignition "OFF" for at least one second, then back "ON". Diagnosis mode is returned to User mode.

If switching Diagnosis mode to User mode is required while malfunction is being detected, by turning ignition switch as follows:

- 1) Turn ignition switch "ON".
- 2) After "AIR BAG" warning lamp lights for 7 seconds, turn ignition switch "OFF" within 1 second.
- 3) Wait more than 3 seconds.
- 4) Repeat steps 1 to 3 three times.
- 5) Turn ignition switch "ON".

## HOW TO ERASE SELF-DIAGNOSIS RESULTS

### ④ With CONSULT-II

NFRS0043S05

NFRS0043S0501

- "SELF-DIAG [CURRENT]"  
A current Self-diagnosis result is displayed on the CONSULT-II screen in real time.

# SUPPLEMENTAL RESTRAINT SYSTEM (SRS)

## Trouble Diagnoses Introduction (Cont'd)

After the malfunction is repaired completely, no malfunction is detected on "SELF-DIAG [CURRENT]".

- "SELF-DIAG [PAST]"  
Return to the "SELF-DIAG [CURRENT]" CONSULT-II screen by pushing "BACK" key of CONSULT-II and select "SELF-DIAG [CURRENT]" in SELECT DIAG MODE. Touch "ERASE" in "SELF-DIAG [CURRENT]" mode.

### NOTE:

If the memory of the malfunction in "SELF-DIAG [PAST]" is not erased, the User mode shows the system malfunction by the operation of the warning lamp even if the malfunction is repaired completely.

SELF-DIAG [CURRENT]	
DTC RESULTS:	
NO DTC IS DETECTED. FURTHER TESTING MAY BE REQUIRED.	

SRS701

- "TROUBLE DIAG RECORD"  
The memory of "TROUBLE DIAG RECORD" cannot be erased.

### ⊗ Without CONSULT-II

After a malfunction is repaired, switch the ignition "OFF" for at least one second, then back "ON". Diagnosis mode returns to the User mode. At that time, the self-diagnostic result is cleared.

NFRS0043S0502

# SUPPLEMENTAL RESTRAINT SYSTEM (SRS)

How to Perform Trouble Diagnoses for Quick and Accurate Repair

## How to Perform Trouble Diagnoses for Quick and Accurate Repair

A good understanding of the malfunction conditions can make troubleshooting faster and more accurate. In general, each customer feels differently about a malfunction. It is important to fully understand the symptoms or conditions for a customer complaint.

=NFRS0044

GI

### INFORMATION FROM CUSTOMER

WHAT ..... Vehicle model

WHEN ..... Date, Frequencies

WHERE ..... Road conditions

HOW ..... Operating conditions, Symptoms

NFRS0044S01

MA

EM

LC

### PRELIMINARY CHECK

Check that the following parts are in good order.

- Battery [Refer to SC-3, "BATTERY".]
- Fuse [Refer to EL-17, "Fuse", "POWER SUPPLY ROUTING".]
- System component-to-harness connections

NFRS0044S02

EC

FE

CL

MT

AT

AX

SU

BR

ST

**RS**

BT

HA

SC

EL

IDX

# SUPPLEMENTAL RESTRAINT SYSTEM (SRS)

How to Perform Trouble Diagnoses for Quick and Accurate Repair (Cont'd)

=NFRS0044S03

## WORK FLOW

### NOTE:

Seat belt pre-tensioner malfunction is indicated by "AIR BAG" warning lamp.

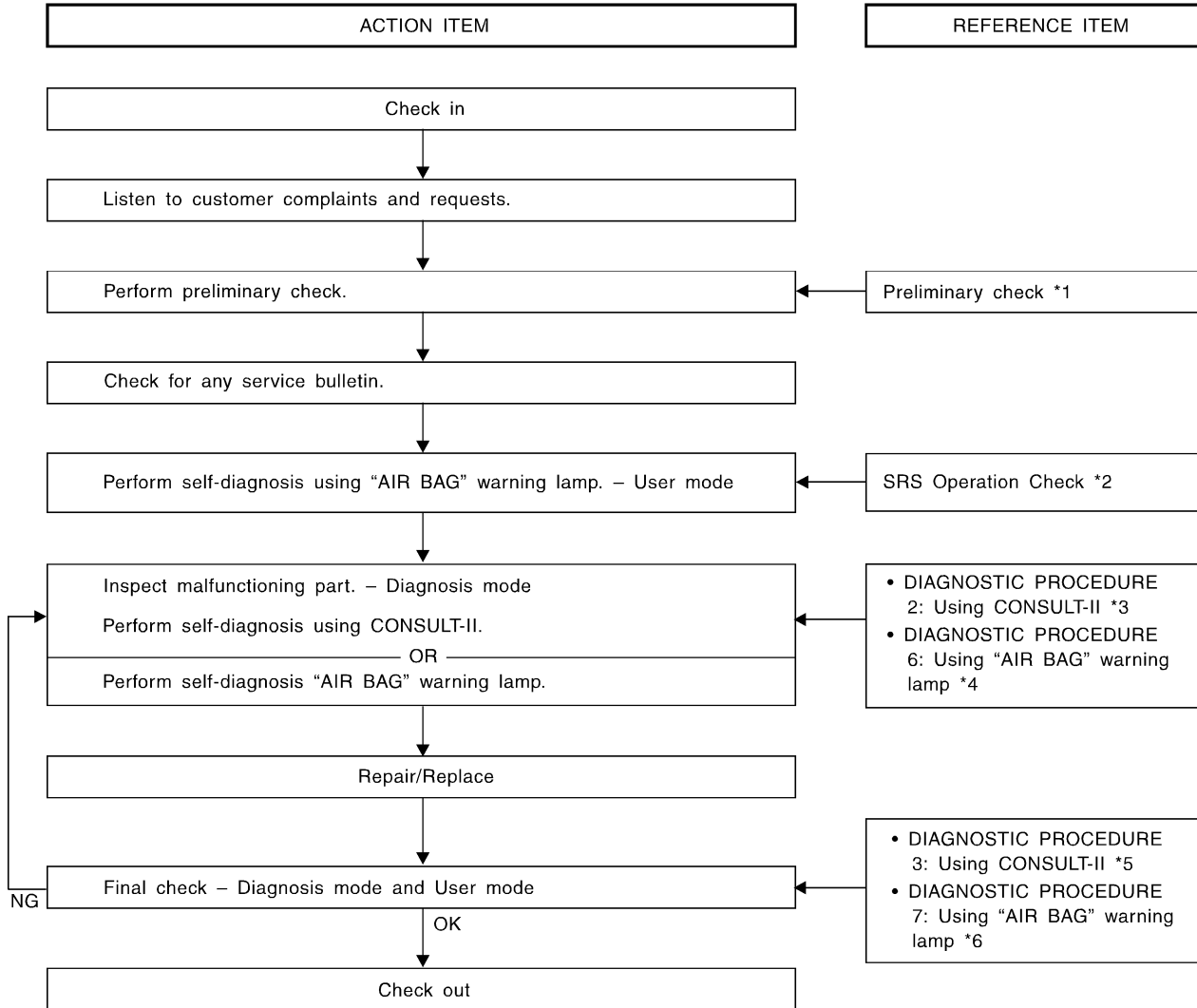

SRS799

\*1: RS-35  
\*2: RS-41

\*3: RS-42  
\*4: RS-51

\*5: RS-45  
\*6: RS-56

# SUPPLEMENTAL RESTRAINT SYSTEM (SRS)

Schematic

NFRS0045

## Schematic

(SA) : With side air bag system

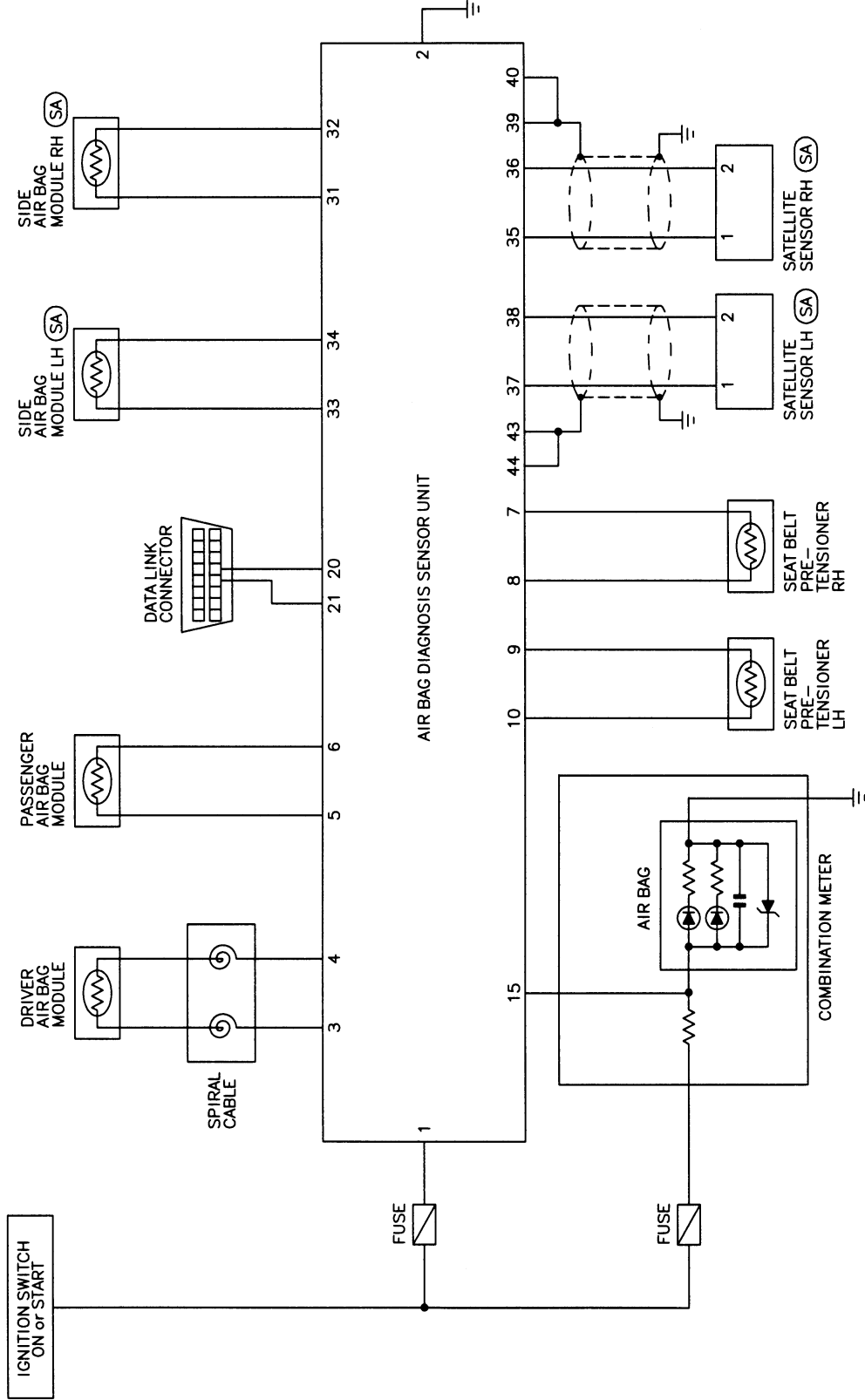

- GI
- MA
- EM
- LC
- EC
- FE
- CL
- MT
- AT
- AX
- SU
- BR
- ST
- RS**
- BT
- HA
- SC
- EL
- IDX

MRS316A

# SUPPLEMENTAL RESTRAINT SYSTEM (SRS)

Wiring Diagram — SRS —

## Wiring Diagram — SRS —

NFRS0046

RS-SRS-01

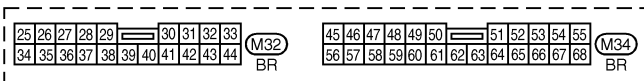
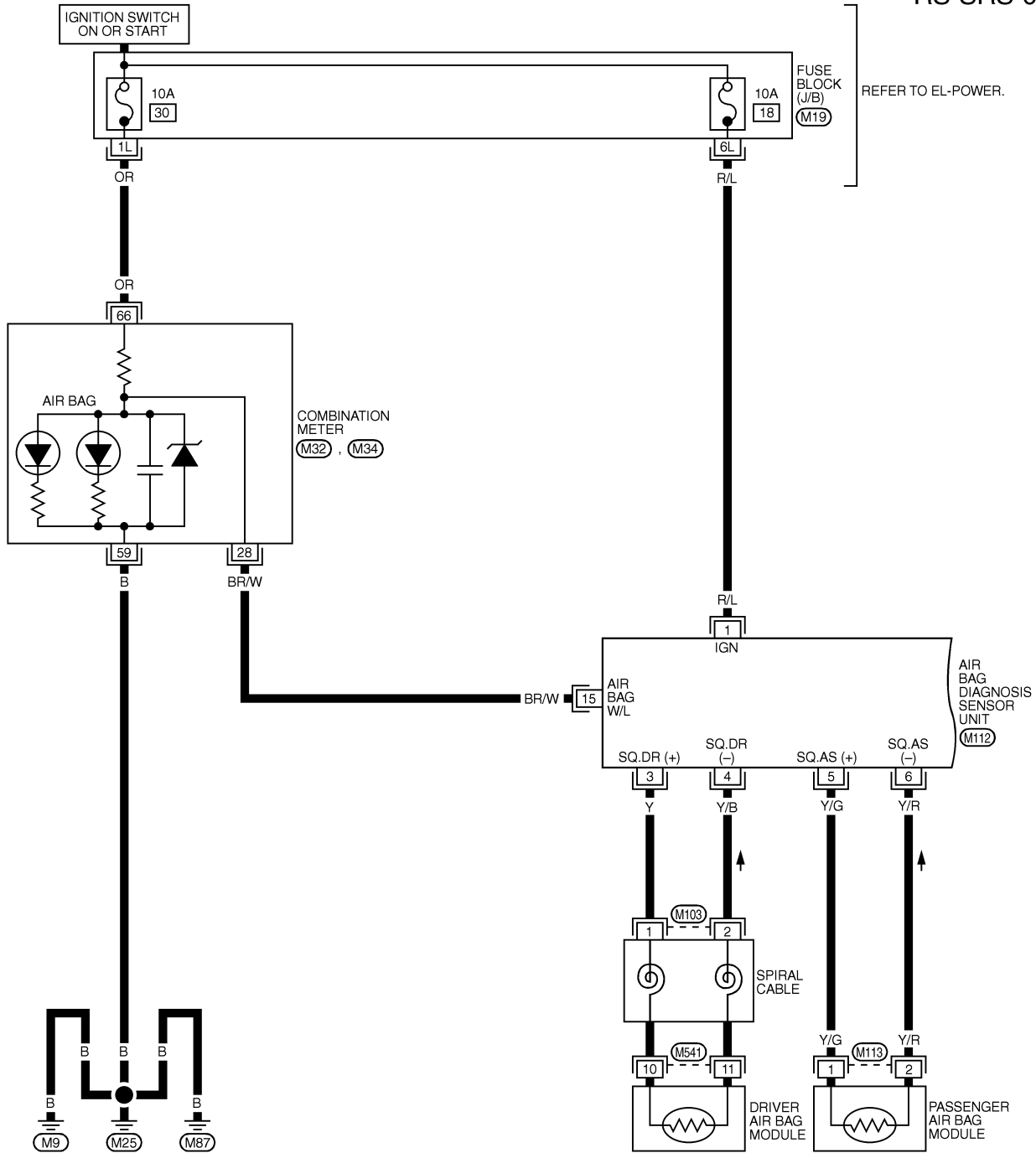

\*: THIS CONNECTOR IS NOT SHOWN IN "HARNESS LAYOUT" OF EL SECTION.

REFER TO THE FOLLOWING.

(M19) - FUSE BLOCK- JUNCTION BOX (J/B)

MRS314A

# SUPPLEMENTAL RESTRAINT SYSTEM (SRS)

Wiring Diagram — SRS — (Cont'd)

RS-SRS-02

◁SA : WITH SIDE AIR BAG SYSTEM

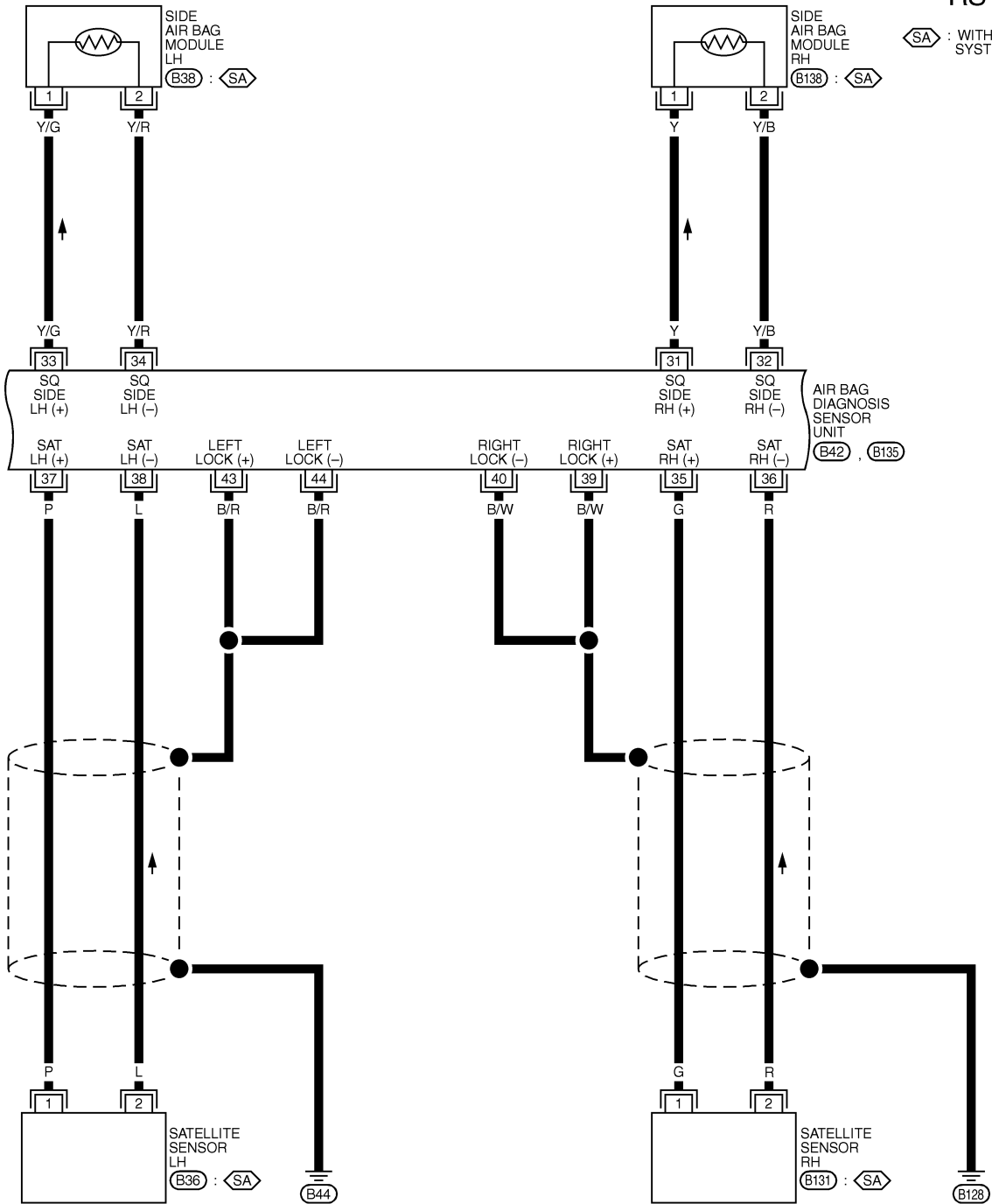

GI  
MA  
EM  
LC  
EC  
FE  
CL  
MT  
AT  
AX  
SU  
BR  
ST  
**RS**  
BT  
HA  
SC  
EL  
IDX

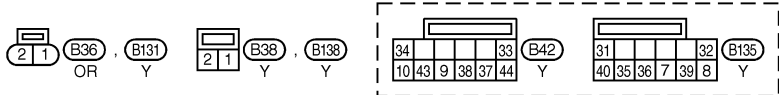

MRS269A

# SUPPLEMENTAL RESTRAINT SYSTEM (SRS)

Wiring Diagram — SRS — (Cont'd)

RS-SRS-03

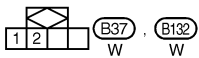
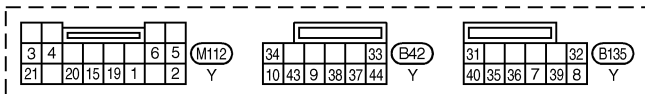
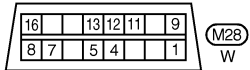
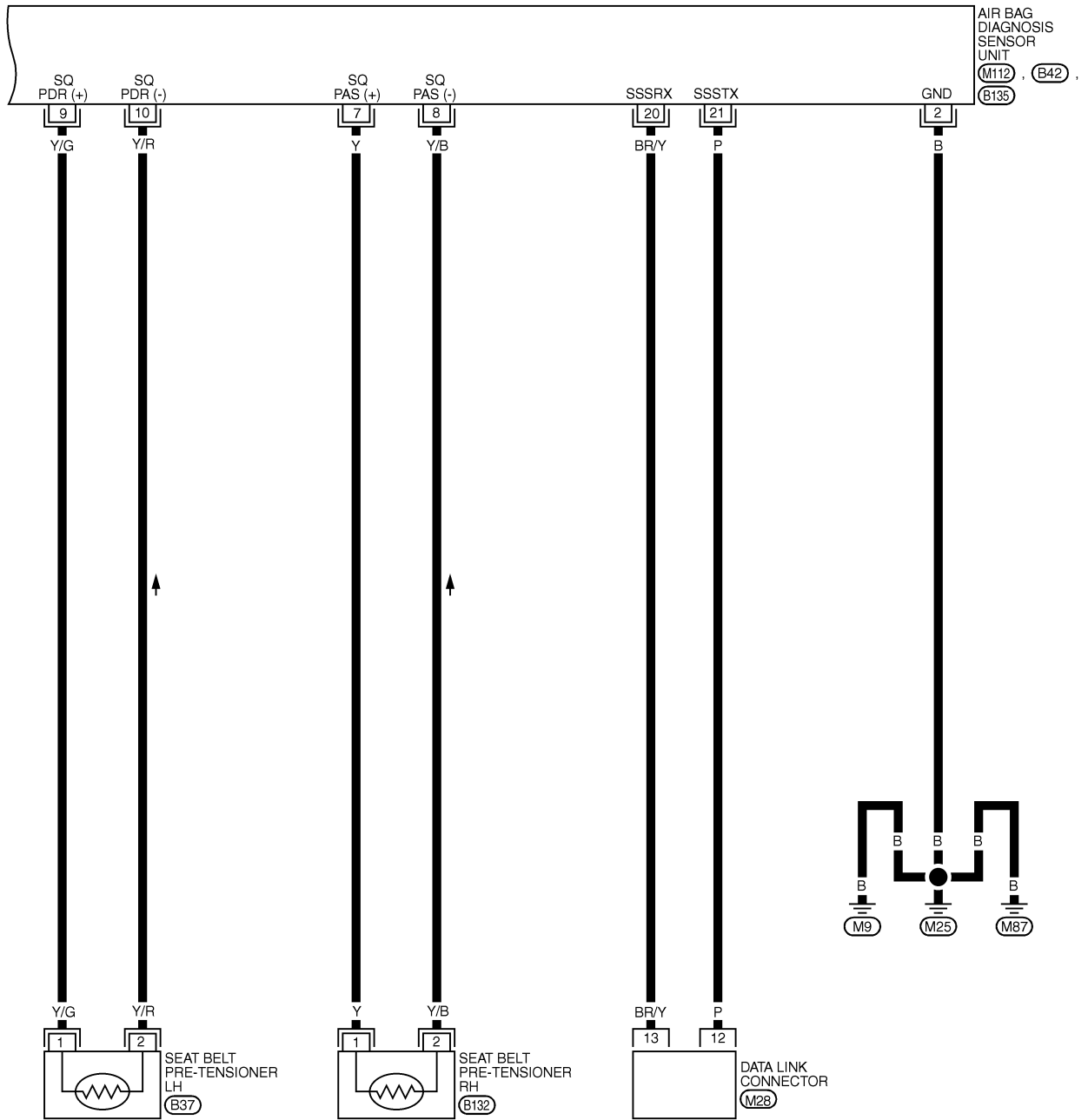

MRS317A



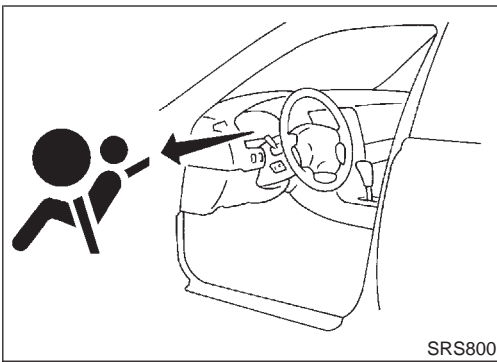

## SRS Operation Check DIAGNOSTIC PROCEDURE 1 Checking Air Bag Operation by Using “AIR BAG” Warning Lamp — User Mode

NFRS0047

NFRS0047S01

NFRS0047S0101

1. After turning ignition switch from “OFF” to “ON”, “AIR BAG” warning lamp operates.
2. Compare “AIR BAG” warning lamp operation to the chart below.

“AIR BAG” warning lamp operation — User mode —	SRS condition	Reference item
<p>MRS095A</p>	No malfunction is detected. No further action is necessary.	—
<p>MRS096A</p>	The system is malfunctioning and needs to be repaired as indicated.	Go to DIAGNOSTIC PROCEDURE 2 or 6 (RS-42 or RS-51).
<p>MRS097A</p>	Air bag is deployed. Seat belt pre-tensioner is deployed.	Go to COLLISION DIAGNOSIS (RS-62).
<p>MRS098A</p>	Air bag fuse, diagnosis sensor unit or harness is malfunctioning and needs to be repaired.	Go to DIAGNOSTIC PROCEDURE 9 (RS-59).
<p>MRS098A</p>	One of the following has occurred and needs to be repaired. <ul style="list-style-type: none"> <li>• Meter fuse is blown.</li> <li>• “AIR BAG” warning lamp circuit has open or short.</li> <li>• Diagnosis sensor unit is malfunctioning.</li> </ul>	Go to DIAGNOSTIC PROCEDURE 10 (RS-61).

**NOTE:**  
If “AIR BAG” warning lamp operates differently from the operations shown above, refer to “AIR BAG” warning lamp operation — Diagnosis mode —, DIAGNOSTIC PROCEDURE 6 (step 4), RS-51.

GI  
MA  
EM  
LC  
EC  
FE  
CL  
MT  
AT  
AX  
SU  
BR  
ST  
RS  
BT  
HA  
SC  
EL  
IDX

# SUPPLEMENTAL RESTRAINT SYSTEM (SRS)

 Trouble Diagnoses with CONSULT-II

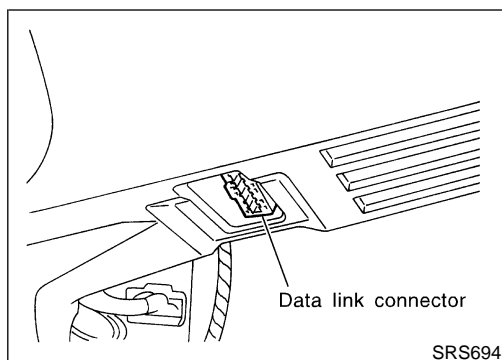

## Trouble Diagnoses with CONSULT-II

=NFRS0048

### DIAGNOSTIC PROCEDURE 2

NFRS0048S01

#### Inspecting SRS malfunctioning parts by using CONSULT-II — Diagnosis mode

1. Turn ignition switch "OFF".
2. Connect "CONSULT-II" to data link connector.

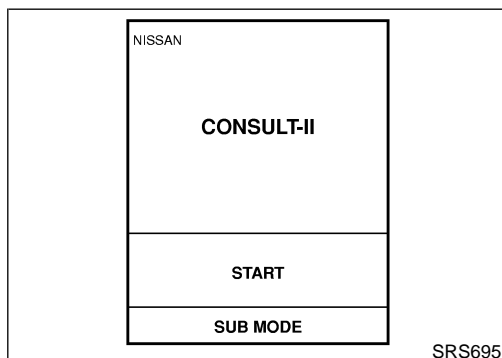

3. Turn ignition switch "ON".
4. Touch "START".

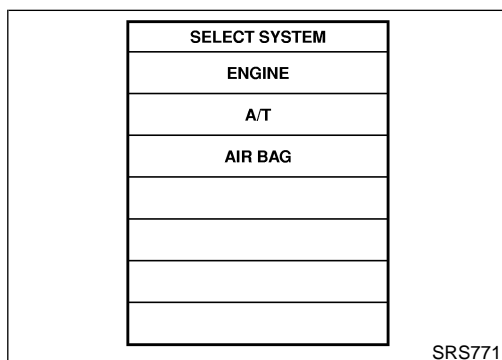

5. Touch "AIR BAG".

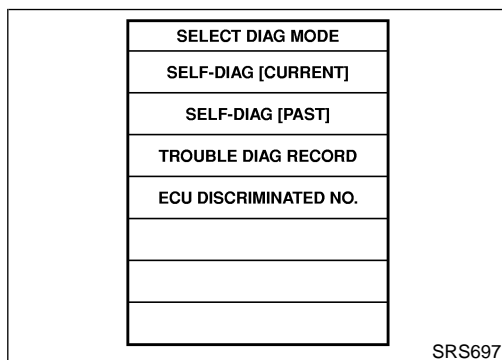

6. Touch "SELF-DIAG [CURRENT]".

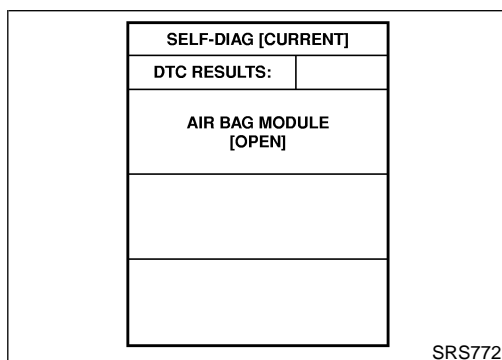

7. Diagnostic codes are displayed on "SELF-DIAG [CURRENT]".

# SUPPLEMENTAL RESTRAINT SYSTEM (SRS)

 Trouble Diagnoses with CONSULT-II (Cont'd)

SELF-DIAG [CURRENT]	
DTC RESULTS:	
NO DTC IS DETECTED. FURTHER TESTING MAY BE REQUIRED.	

SRS701

If no malfunction is detected on “SELF-DIAG [CURRENT]” even though malfunction is detected in “SRS Operation Check”, check the battery voltage.

If the battery voltage is less than 9V, charge the battery. Then go to DIAGNOSTIC PROCEDURE 3, page RS-45.

If the battery voltage is OK, go to DIAGNOSTIC PROCEDURE 4, page RS-47, to diagnose the following cases:

- Self-diagnostic result “SELF-DIAG [PAST]” (previously stored in the memory) might not be erased after repair.
- The SRS system malfunctions intermittently.

8. Touch “PRINT”.
9. Compare diagnostic codes to “CONSULT-II Diagnostic Code Chart”, page RS-43.
10. Touch “BACK” key of CONSULT-II until “SELECT SYSTEM” appears in order to return to User mode from Diagnosis mode.
11. Turn ignition switch “OFF”, then turn off and disconnect CONSULT-II, and disconnect both battery cables.
12. Repair the system as outlined by the “Repair order” in “CONSULT-II Diagnostic Code Chart”, that corresponds to the self-diagnostic result. For replacement procedure of component parts, refer to RS-18.
13. After repairing the system, go to DIAGNOSTIC PROCEDURE 3, page RS-45 for final checking.

## CONSULT-II Diagnostic Code Chart (“SELF-DIAG [CURRENT]”)

NFRS0048S0101

Diagnostic item	Explanation	Repair order “Recheck SRS at each replacement.”
NO DTC IS DETECTED.	When malfunction is indicated by the “AIR BAG” warning lamp in User mode	<ul style="list-style-type: none"> <li>• Low battery voltage (Less than 9V)</li> <li>• Self-diagnostic result “SELF-DIAG [PAST]” (previously stored in the memory) might not be erased after repair.</li> <li>• Intermittent malfunction has been detected in the past.</li> </ul>
	<ul style="list-style-type: none"> <li>• No malfunction is detected.</li> </ul>	<ul style="list-style-type: none"> <li>• Go to DIAGNOSTIC PROCEDURE 3 (RS-45) after charging battery.</li> <li>• Go to DIAGNOSTIC PROCEDURE 4 (RS-47).</li> <li>• Go to DIAGNOSTIC PROCEDURE 3 (RS-45).</li> </ul>
AIRBAG MODULE [OPEN]	<ul style="list-style-type: none"> <li>• Driver’s air bag module circuit is open. (including the spiral cable)</li> </ul>	<ol style="list-style-type: none"> <li>1. Visually check the wiring harness connection.</li> <li>2. Replace the harness if it has visible damage.</li> <li>3. Replace driver’s air bag module. (Before disposal of it, it must be deployed.)</li> <li>4. Replace the spiral cable.</li> <li>5. Replace the diagnosis sensor unit.</li> <li>6. Replace the related harness.</li> </ol>

## SUPPLEMENTAL RESTRAINT SYSTEM (SRS)

 Trouble Diagnoses with CONSULT-II (Cont'd)

Diagnostic item	Explanation	Repair order “Recheck SRS at each replacement.”
AIRBAG MODULE [VB-SHORT]	● Driver's air bag module circuit is shorted to some power supply circuit. (including the spiral cable)	1. Visually check the wiring harness connection. 2. Replace the harness if it has visible damage.
AIRBAG MODULE [GND-SHORT]	● Driver's air bag module circuit is shorted to ground. (including the spiral cable)	3. Replace the spiral cable. 4. Replace driver's air bag module. (Before disposal of it, it must be deployed.)
AIRBAG MODULE [SHORT]	● Driver's air bag module circuits are shorted to each other.	5. Replace the diagnosis sensor unit. 6. Replace the related harness.
ASSIST A/B MODULE [VB-SHORT]	● Front passenger air bag module circuit is shorted to some power supply circuit.	1. Visually check the wiring harness connection. 2. Replace the harness if it has visible damage.
ASSIST A/B MODULE [OPEN]	● Front passenger air bag module circuit is open.	3. Replace front passenger air bag module. (Before disposal of it, it must be deployed.)
ASSIST A/B MODULE [GND-SHORT]	● Front passenger air bag module circuit is shorted to ground.	4. Replace the diagnosis sensor unit.
ASSIST A/B MODULE [SHORT]	● Front passenger air bag module circuits are shorted to each other.	5. Replace the related harness.
SIDE MODULE LH [OPEN]	● Side air bag module (LH) circuit is open.	1. Visually check the wiring harness connection. 2. Replace the harness if it has visible damage.
SIDE MODULE LH [VB-SHORT]	● Side air bag module (LH) circuit is shorted to some power supply circuits.	3. Replace side air bag module (LH). (Before disposal, it must be deployed.)
SIDE MODULE LH [GND-SHORT]	● Side air bag module (LH) circuit is shorted to ground.	4. Replace the diagnosis sensor unit.
SIDE MODULE LH [SHORT]	● Side air bag module (LH) circuits are shorted to each other.	5. Replace the related harness.
SIDE MODULE RH [OPEN]	● Side air bag module (RH) circuit is open.	1. Visually check the wiring harness connection. 2. Replace the harness if it has visible damage.
SIDE MODULE RH [VB-SHORT]	● Side air bag module (RH) circuit is shorted to some power supply circuits.	3. Replace side air bag module (RH). (Before disposal, it must be deployed.)
SIDE MODULE RH [GND-SHORT]	● Side air bag module (RH) circuit is shorted to ground.	4. Replace the diagnosis sensor unit.
SIDE MODULE RH [SHORT]	● Side air bag module (RH) circuits are shorted to each other.	5. Replace the related harness.
SATELLITE SENS LH [UNIT FAIL] SATELLITE SENS LH [COMM FAIL]	● Satellite sensor (LH)	1. Visually check the wiring harness connection. 2. Replace the harness if it has visible damage. 3. Replace the satellite sensor (LH). 4. Replace the diagnosis sensor unit. 5. Replace the related harness.
SATELLITE SENS RH [UNIT FAIL] SATELLITE SENS RH [COMM FAIL]	● Satellite sensor (RH)	1. Visually check the wiring harness connection. 2. Replace the harness if it has visible damage. 3. Replace the satellite sensor (RH). 4. Replace the diagnosis sensor unit. 5. Replace the related harness.

# SUPPLEMENTAL RESTRAINT SYSTEM (SRS)

 Trouble Diagnoses with CONSULT-II (Cont'd)

Diagnostic item	Explanation	Repair order "Recheck SRS at each replacement."	
PRE-TEN FRONT LH [OPEN/VB-SHORT]	<ul style="list-style-type: none"> <li>The circuit for front LH pre-tensioner is open or shorted to some power supply circuit.</li> </ul>	<ol style="list-style-type: none"> <li>1. Visually check the wiring harness connections.</li> <li>2. Replace the harness if it has visible damage.</li> </ol>	GI MA
PRE-TEN FRONT LH [GND-SHORT]	<ul style="list-style-type: none"> <li>The circuit for front LH pre-tensioner is shorted to ground.</li> </ul>	<ol style="list-style-type: none"> <li>3. Replace front LH seat belt. (Before disposing, it must be deactivated.)</li> <li>4. Replace the diagnosis sensor unit.</li> <li>5. Replace the related harness.</li> </ol>	EM LC
PRE-TEN FRONT RH [OPEN/VB-SHORT]	<ul style="list-style-type: none"> <li>The circuit for front RH pre-tensioner is open or shorted to some power supply circuit.</li> </ul>	<ol style="list-style-type: none"> <li>1. Visually check the wiring harness connections.</li> <li>2. Replace the harness if it has visible damage.</li> </ol>	EC
PRE-TEN FRONT RH [GND-SHORT]	<ul style="list-style-type: none"> <li>The circuit for front RH pre-tensioner is shorted to ground.</li> </ul>	<ol style="list-style-type: none"> <li>3. Replace front RH seat belt. (Before disposing, it must be deactivated.)</li> <li>4. Replace the diagnosis sensor unit.</li> <li>5. Replace the related harness.</li> </ol>	FE CL
CONTROL UNIT	<ul style="list-style-type: none"> <li>Diagnosis sensor unit is malfunctioning.</li> </ul>	<ol style="list-style-type: none"> <li>1. Visually check the wiring harness connection.</li> <li>2. Replace the diagnosis sensor unit.</li> </ol>	MT

\* Follow the procedures in numerical order when repairing malfunctioning parts. Confirm whether malfunction is eliminated using the air bag warning lamp or CONSULT-II each time repair is finished. If malfunction is still observed, proceed to the next step. When malfunction is eliminated, further repair work is not required.

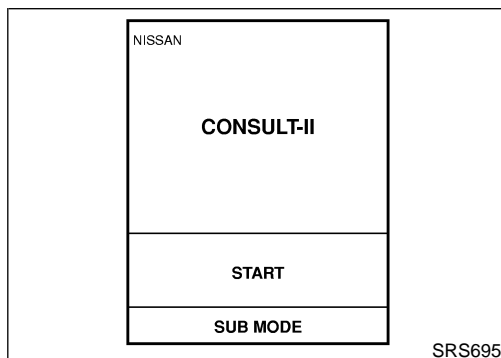
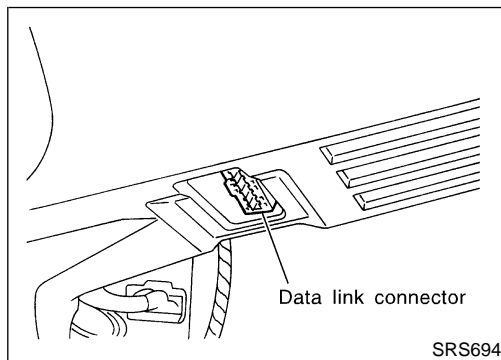

## DIAGNOSTIC PROCEDURE 3

<sup>NFRS0048S02</sup> Final checking after repairing SRS by using CONSULT-II — Diagnosis mode

1. After repairing SRS, connect both battery cables.
2. Connect CONSULT-II to Data link connector.
3. Turn ignition switch from "OFF" to "ON".
4. Touch "START".

GI  
MA  
EM  
LC  
EC  
FE  
CL  
MT  
AT  
AX  
SU  
BR  
ST  
RS  
BT  
HA  
SC  
EL  
IDX

# SUPPLEMENTAL RESTRAINT SYSTEM (SRS)

 Trouble Diagnoses with CONSULT-II (Cont'd)

SELECT SYSTEM
ENGINE
A/T
AIR BAG

SRS771

5. Touch "AIR BAG".

SELECT DIAG MODE
SELF-DIAG [CURRENT]
SELF-DIAG [PAST]
TROUBLE DIAG RECORD
ECU DISCRIMINATED NO.

SRS697

6. Touch "SELF-DIAG [CURRENT]".

SELF-DIAG [CURRENT]
DTC RESULTS:
NO DTC IS DETECTED. FURTHER TESTING MAY BE REQUIRED.

SRS701

7. If no malfunction is detected on "SELF-DIAG [CURRENT]", repair of SRS is completed. Go to step 8.  
If any malfunction is displayed on "SELF-DIAG [CURRENT]", the malfunctioning part is not repaired completely or another malfunctioning part is detected. Go to DIAGNOSTIC PROCEDURE 2, page RS-42, and repair malfunctioning part completely.

SELF-DIAG [CURRENT]
DTC RESULTS:
AIR BAG MODULE [OPEN]
ERASE

SRS773

8. Touch "ERASE".

**NOTE:**

**Touch "ERASE" to clear the memory of the malfunction ("SELF-DIAG [PAST])."**

If the memory of the malfunction in "SELF-DIAG [PAST]" is not erased, the User mode shows the system malfunction by the operation of the warning lamp even if the malfunction is repaired completely.

SELECT DIAG MODE
SELF-DIAG [CURRENT]
SELF-DIAG [PAST]
TROUBLE DIAG RECORD
ECU DISCRIMINATED NO.

SRS697

9. Touch "BACK" key of CONSULT-II to "SELECT SYSTEM" screen. Touch "SELF-DIAG [PAST]".

# SUPPLEMENTAL RESTRAINT SYSTEM (SRS)

 Trouble Diagnoses with CONSULT-II (Cont'd)

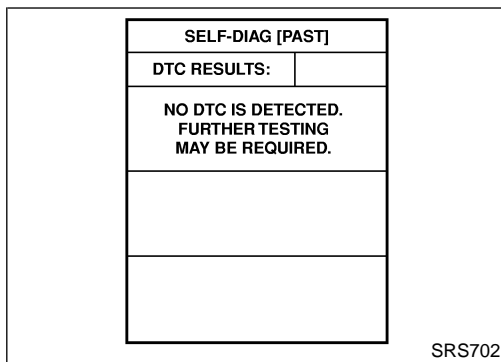

SRS702

10. Check that no malfunction is detected on “SELF-DIAG [PAST]”.

11. Touch “BACK” key of CONSULT-II until “SELECT SYSTEM” appears in order to return to User mode from Diagnosis mode.
12. Turn ignition switch “OFF”, then turn off and disconnect CONSULT-II.
13. Go to “SRS Operation Check”, page RS-41 to check SRS operation by using “AIR BAG” warning lamp with User mode.

## DIAGNOSTIC PROCEDURE 4 (CONTINUED FROM DIAGNOSTIC PROCEDURE 2)

NFRS0048S03

### Inspecting SRS malfunctioning record

<b>1</b>	<b>CONSIDER POSSIBILITY OF NOT ERASING SELF-DIAGNOSTIC RESULT AFTER REPAIRING</b>	
Is it the first time for maintenance of SRS?		
Yes or No		
Yes	▶	Go to DIAGNOSTIC PROCEDURE 5 (RS-47).
No	▶	Self-diagnostic result “SELF-DIAG [PAST]” (previously stored in the memory) might not be erased after repair. Go to DIAGNOSTIC PROCEDURE 3, step 8 (RS-45).

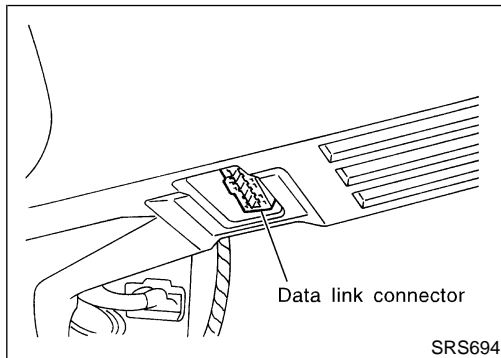

SRS694

## DIAGNOSTIC PROCEDURE 5

NFRS0048S04

### Inspecting SRS intermittent malfunction by using CONSULT-II — Diagnosis mode

1. Turn ignition switch “OFF”.
2. Connect “CONSULT-II” to Data link connector.

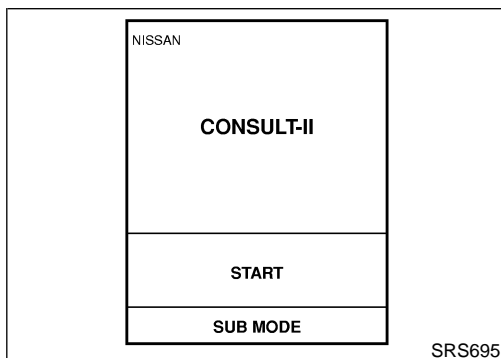

SRS695

3. Turn ignition switch “ON”.
4. Touch “START”.

GI  
MA  
EM  
LC  
EC  
FE  
CL  
MT  
AT  
AX  
SU  
BR  
ST  
RS  
BT  
HA  
SC  
EL  
IDX

# SUPPLEMENTAL RESTRAINT SYSTEM (SRS)

 Trouble Diagnoses with CONSULT-II (Cont'd)

SELECT SYSTEM
ENGINE
A/T
AIR BAG

SRS771

5. Touch "AIR BAG".

SELECT DIAG MODE
SELF-DIAG [CURRENT]
SELF-DIAG [PAST]
TROUBLE DIAG RECORD
ECU DISCRIMINATED NO.

SRS697

6. Touch "SELF-DIAG [PAST]".

SELF-DIAG [PAST]
DTC RESULTS: <input type="text"/>
AIR BAG MODULE [OPEN]

SRS700

7. If diagnostic codes are displayed on "SELF-DIAG [PAST]", go to step 10.

SELF-DIAG [PAST]
DTC RESULTS: <input type="text"/>
NO DTC IS DETECTED. FURTHER TESTING MAY BE REQUIRED.

SRS702

If no malfunction is detected on "SELF-DIAG [PAST]", touch "BACK" and go back to "SELECT DIAG MODE".

SELECT DIAG MODE
SELF-DIAG [CURRENT]
SELF-DIAG [PAST]
TROUBLE DIAG RECORD
ECU DISCRIMINATED NO.

SRS697

8. Touch "TROUBLE DIAG RECORD".

**NOTE:**  
With "TROUBLE DIAG RECORD", diagnosis results previously erased by a reset operation can be displayed.



# SUPPLEMENTAL RESTRAINT SYSTEM (SRS)

 Trouble Diagnoses with CONSULT-II (Cont'd)

TROUBLE DIAG RECORD	
DTC RESULTS:	
AIR BAG MODULE [OPEN]	

SRS704

9. Diagnostic code is displayed on "TROUBLE DIAG RECORD".

10. Touch "PRINT".
11. Compare diagnostic codes to "Intermittent Malfunction Diagnostic Code Chart", page RS-49.
12. Touch "BACK" key of CONSULT-II until "SELECT SYSTEM" appears.
13. Turn ignition switch "OFF", then turn off and disconnect CONSULT-II, and disconnect both battery cables.
14. Repair the system as outlined by the "Repair order" in "Intermittent Malfunction Diagnostic Code Chart", that corresponds to the self-diagnostic result. For replacement procedure of component parts, refer to RS-18.
15. Go to DIAGNOSTIC PROCEDURE 3, page RS-45, for final checking.

## Intermittent Malfunction Diagnostic Code Chart ("SELF-DIAG [PAST]" or "TROUBLE DIAG RECORD")

NFRS0048S0401

Diagnostic item	Explanation	Repair order
NO DTC IS DETECTED.	When malfunction is indicated by the "AIR BAG" warning lamp in User mode <ul style="list-style-type: none"> <li>● Low battery voltage (Less than 9V)</li> </ul>	<ul style="list-style-type: none"> <li>● Go to DIAGNOSTIC PROCEDURE 3 (RS-45) after charging battery.</li> </ul>
	<ul style="list-style-type: none"> <li>● No malfunction is detected.</li> </ul>	<ul style="list-style-type: none"> <li>● Go to DIAGNOSTIC PROCEDURE 3 (RS-45).</li> </ul>
AIRBAG MODULE [OPEN]	<ul style="list-style-type: none"> <li>● Driver's air bag module circuit is open. (including the spiral cable)</li> </ul>	<ol style="list-style-type: none"> <li>1. Visually check the wiring harness connection.</li> <li>2. Replace the harness if it has visible damage.</li> <li>3. If the harness check result is OK, replace driver's air bag module (Before disposal of it, it must be deployed.), diagnosis sensor unit and spiral cable.</li> </ol>
AIRBAG MODULE [VB-SHORT]	<ul style="list-style-type: none"> <li>● Driver's air bag module circuit is shorted to some power supply circuit. (including the spiral cable)</li> </ul>	
AIRBAG MODULE [GND-SHORT]	<ul style="list-style-type: none"> <li>● Driver's air bag module circuit is shorted to ground. (including the spiral cable)</li> </ul>	
AIRBAG MODULE [SHORT]	<ul style="list-style-type: none"> <li>● Driver's air bag module circuits are shorted to each other.</li> </ul>	
ASSIST A/B MODULE [VB-SHORT]	<ul style="list-style-type: none"> <li>● Front passenger air bag module circuit is shorted to some power supply circuit.</li> </ul>	<ol style="list-style-type: none"> <li>1. Visually check the wiring harness connection.</li> <li>2. Replace the harness if it has visible damage.</li> <li>3. If the harness check result is OK, replace front air bag module (Before disposal of it, it must be deployed.), and diagnosis sensor unit.</li> </ol>
ASSIST A/B MODULE [OPEN]	<ul style="list-style-type: none"> <li>● Front passenger air bag module circuit is open.</li> </ul>	
ASSIST A/B MODULE [GND-SHORT]	<ul style="list-style-type: none"> <li>● Front passenger air bag module circuit is shorted to ground.</li> </ul>	
ASSIST A/B MODULE [SHORT]	<ul style="list-style-type: none"> <li>● Front passenger air bag module circuits are shorted to each other.</li> </ul>	

## SUPPLEMENTAL RESTRAINT SYSTEM (SRS)

 Trouble Diagnoses with CONSULT-II (Cont'd)

Diagnostic item	Explanation	Repair order
SIDE MODULE LH [OPEN]	<ul style="list-style-type: none"> <li>● Side air bag module (LH) circuit is open.</li> </ul>	<ol style="list-style-type: none"> <li>1. Visually check the wiring harness connection.</li> <li>2. Replace the harness if it has visible damage.</li> <li>3. If the harness check is OK, replace the diagnosis sensor unit and side air bag module (LH). (Before disposing the side air bag module (LH), it must be deployed.)</li> </ol>
SIDE MODULE LH [VB-SHORT]	<ul style="list-style-type: none"> <li>● Side air bag module (LH) circuit is shorted to some power supply circuits.</li> </ul>	
SIDE MODULE LH [GND-SHORT]	<ul style="list-style-type: none"> <li>● Side air bag module (LH) circuit is shorted to ground.</li> </ul>	
SIDE MODULE LH [SHORT]	<ul style="list-style-type: none"> <li>● Side air bag module (LH) circuits are shorted to each other.</li> </ul>	
SIDE MODULE RH [OPEN]	<ul style="list-style-type: none"> <li>● Side air bag module (RH) circuit is open.</li> </ul>	<ol style="list-style-type: none"> <li>1. Visually check the wiring harness connection.</li> <li>2. Replace the harness if it has visible damage.</li> <li>3. If the harness check is OK, replace the diagnosis sensor unit and side air bag module (RH). (Before disposing the side air bag module (RH), it must be deployed.)</li> </ol>
SIDE MODULE RH [VB-SHORT]	<ul style="list-style-type: none"> <li>● Side air bag module (RH) circuit is shorted to some power supply circuits.</li> </ul>	
SIDE MODULE RH [GND-SHORT]	<ul style="list-style-type: none"> <li>● Side air bag module (RH) circuit is shorted to ground.</li> </ul>	
SIDE MODULE RH [SHORT]	<ul style="list-style-type: none"> <li>● Side air bag module (RH) circuits are shorted to each other.</li> </ul>	
SATELLITE SENS LH [UNIT FAIL] SATELLITE SENS LH [COMM FAIL]	<ul style="list-style-type: none"> <li>● Satellite sensor (LH)</li> </ul>	<ol style="list-style-type: none"> <li>1. Visually check the wiring harness connection.</li> <li>2. Replace the harness if it has visible damage.</li> <li>3. If the harness check is OK, replace the diagnosis sensor unit and satellite sensor (LH).</li> </ol>
SATELLITE SENS RH [UNIT FAIL] SATELLITE SENS RH [COMM FAIL]	<ul style="list-style-type: none"> <li>● Satellite sensor (RH)</li> </ul>	<ol style="list-style-type: none"> <li>1. Visually check the wiring harness connection.</li> <li>2. Replace the harness if it has visible damage.</li> <li>3. If the harness check is OK, replace the diagnosis sensor unit and satellite sensor (RH).</li> </ol>
PRE-TEN FRONT LH [OPEN/VB-SHORT]	<ul style="list-style-type: none"> <li>● The circuit for front LH pre-tensioner is open or shorted to some power supply circuit.</li> </ul>	<ol style="list-style-type: none"> <li>1. Visually check the wiring harness connections.</li> <li>2. Replace the harness if it has visible damage.</li> <li>3. If the harness check is OK, replace the diagnosis sensor unit and front LH seat belt. (Before disposing the front LH seat belt pre-tensioner, it must be deployed.)</li> </ol>
PRE-TEN FRONT LH [GND-SHORT]	<ul style="list-style-type: none"> <li>● The circuit for front LH pre-tensioner is shorted to ground.</li> </ul>	
PRE-TEN FRONT RH [OPEN/VB-SHORT]	<ul style="list-style-type: none"> <li>● The circuit for front RH pre-tensioner is open or shorted to some power supply circuit.</li> </ul>	<ol style="list-style-type: none"> <li>1. Visually check the wiring harness connections.</li> <li>2. Replace the harness if it has visible damage.</li> <li>3. If the harness check is OK, replace the diagnosis sensor unit and front RH seat belt. (Before disposing the front RH seat belt pre-tensioner, it must be deployed.)</li> </ol>
PRE-TEN FRONT RH [GND-SHORT]	<ul style="list-style-type: none"> <li>● The circuit for front RH pre-tensioner is shorted to ground.</li> </ul>	

# SUPPLEMENTAL RESTRAINT SYSTEM (SRS)

 Trouble Diagnoses with CONSULT-II (Cont'd)

Diagnostic item	Explanation	Repair order
CONTROL UNIT	<ul style="list-style-type: none"> <li>● Diagnosis sensor unit is malfunctioning.</li> </ul>	<ol style="list-style-type: none"> <li>1. Visually check the wiring harness connection.</li> <li>2. Replace the harness if it has visible damage.</li> <li>3. If the harness check is OK, replace the diagnosis sensor unit.</li> </ol>

\* Follow the procedures in numerical order when repairing malfunctioning parts, then make the final system check.

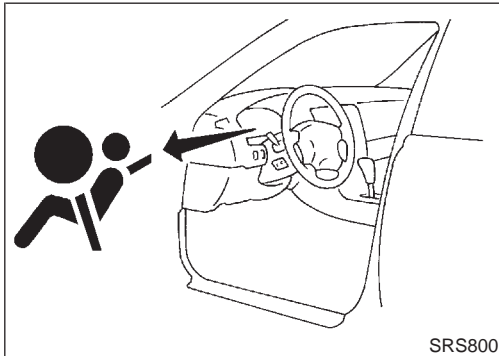

## Trouble Diagnoses without CONSULT-II

### DIAGNOSTIC PROCEDURE 6

Inspecting SRS malfunctioning parts by using "AIR BAG" warning lamp — Diagnosis mode

#### NOTE:

SRS will not enter Diagnosis mode if no malfunction is detected in User mode.

1. Turn ignition switch "ON".
2. After "AIR BAG" warning lamp lights for 7 seconds, turn ignition switch "OFF" within 1 second.
3. Wait more than 3 seconds.
4. Repeat steps 1 to 3 three times.
5. Turn ignition switch "ON".  
SRS is now in Diagnosis mode.
6. "AIR BAG" warning lamp operates in Diagnosis mode as follows:

#### NOTE:

If SRS does not enter Diagnosis mode even though malfunction is detected in User mode, check the battery voltage.

If the battery voltage is less than 9V, charge the battery. Then go to DIAGNOSTIC PROCEDURE 7, page RS-56.

If the battery voltage is OK, replace the diagnosis sensor unit.

GI  
MA  
EM  
LC  
EC  
FE  
CL  
MT  
AT  
AX  
SU  
BR  
ST  
RS  
BT  
HA  
SC  
EL  
IDX

# SUPPLEMENTAL RESTRAINT SYSTEM (SRS)

⊗ Trouble Diagnoses without CONSULT-II (Cont'd)

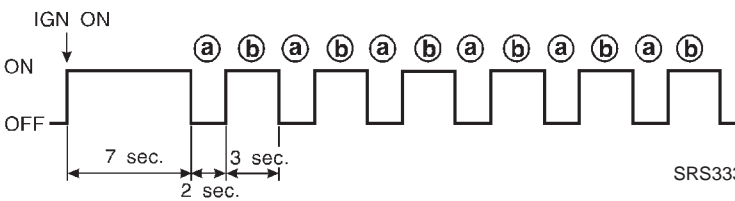
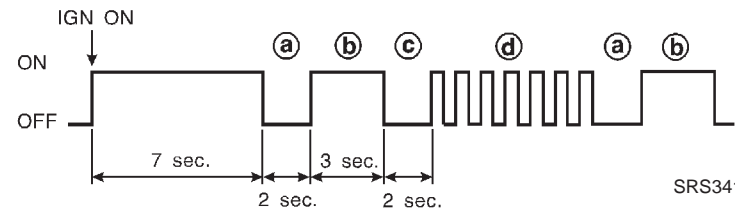
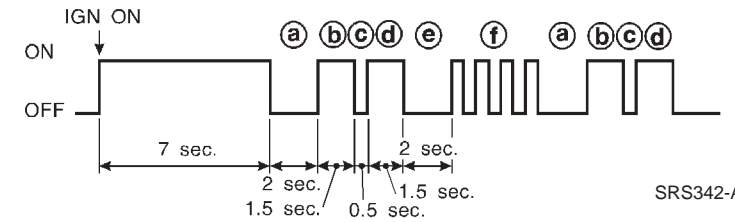
No.	"AIR BAG" warning lamp flash pattern — Diagnosis mode —	SRS condition
1	 <p style="text-align: right;">SRS333</p>	<p>a through b are repeated.</p> <ul style="list-style-type: none"> <li>● Diagnosis results (previously stored in the memory) might not be erased after repair.</li> <li>● Intermittent malfunction has been detected in the past. Go to DIAGNOSTIC PROCEDURE 8 (RS-58).</li> </ul>
2	 <p style="text-align: right;">SRS341</p>	<p>a through d are repeated.</p> <p><b>b</b> — Driver and passenger air bag and seat belt pre-tensioner marker (For identifying driver air bag, passenger air bag and/or seat belt pre-tensioners malfunctioning)</p> <p><b>d</b> — Indicates malfunctioning part. The number of flash varies with malfunctioning part (0.5 sec. ON and 0.5 sec. OFF is counted as one flash.)</p>
3	 <p style="text-align: right;">SRS342-A</p>	<p>a through f are repeated.</p> <p><b>b, c, d</b> — Side air bag marker (For identifying side air bag malfunctioning)</p> <p><b>f</b> — Indicates malfunctioning part. The number of flash varies with malfunctioning part (0.5 sec. ON and 0.5 sec. OFF is counted as one flash.)</p>

- Malfunctioning part is indicated by the number of flashes (part **d** or **f**). Compare the number of flashes to "Air Bag Warning Lamp Flash Code Chart", page RS-53, and locate malfunctioning part.
- Turn ignition switch "OFF", and disconnect both battery cables.
- Repair the system as outlined by the "Repair order" in "Warning Lamp Flash Code Chart" that corresponds to the flash code. For replacement procedure of component parts, refer to RS-18.
- After repairing the system, go to DIAGNOSTIC PROCEDURE 7, page RS-56.

# SUPPLEMENTAL RESTRAINT SYSTEM (SRS)

Trouble Diagnoses without CONSULT-II (Cont'd)

## Air Bag Warning Lamp Flash Code Chart (Diagnosis mode)

NFRS0049S0101

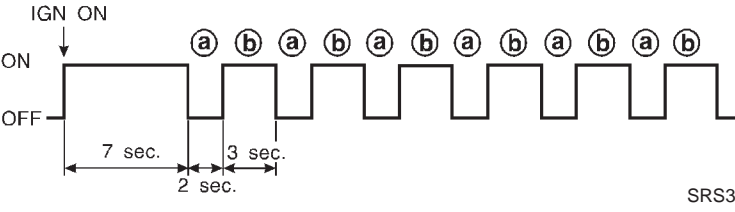
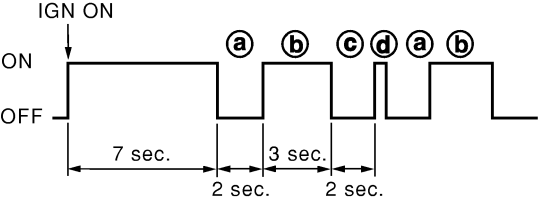
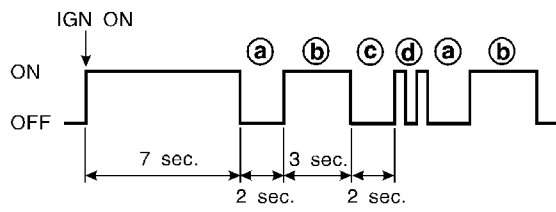
<ul style="list-style-type: none"> <li>• Diagnosis results (previously stored in the memory) might not be erased after repair.</li> <li>• Intermittent malfunction has been detected in the past.</li> </ul>	<p style="text-align: center;">Flash pattern</p>  <p style="text-align: right;">SRS333</p> <p>a through b are repeated.</p>	<p>GI</p> <p>MA</p> <p>EM</p> <p>LC</p>
<p>Repair order</p>		<p>EC</p>
<ul style="list-style-type: none"> <li>• Go to DIAGNOSTIC PROCEDURE 8 (RS-58).</li> </ul>		<p>FE</p>
<p>The front RH seat belt pre-tensioner circuit is malfunctioning. (d: 1 flash)</p>	<p style="text-align: center;">Flash pattern</p>  <p style="text-align: right;">SRS801</p> <p>a through d are repeated. d — One flash indicates malfunctioning front RH pre-tensioner circuit.</p>	<p>CL</p> <p>MT</p> <p>AT</p>
<p>Repair order ("Recheck SRS at each replacement.")</p>		<p>AX</p>
<ol style="list-style-type: none"> <li>1. Visually check the wiring harness connections.</li> <li>2. Replace the harness if it has visible damage.</li> <li>3. Replace front RH seat belt pre-tensioner. (Before disposing, it must be deactivated.)</li> <li>4. Replace the diagnosis sensor unit.</li> <li>5. Replace the related harness.</li> </ol>		<p>SU</p>
<p>The driver's air bag module circuit is malfunctioning. (d: 2 flashes)</p>	<p style="text-align: center;">Flash pattern</p>  <p style="text-align: right;">SRS334</p> <p>a through d are repeated. d — Two flashes indicate malfunctioning driver's air bag module circuit.</p>	<p>ST</p> <p><b>RS</b></p> <p>BT</p> <p>HA</p> <p>SC</p> <p>EL</p>
<p>Repair order ("Recheck SRS at each replacement.")</p>		<p>IDX</p>
<ol style="list-style-type: none"> <li>1. Visually check the wiring harness connection.</li> <li>2. Replace the harness if it has visible damage.</li> <li>3. Replace the spiral cable.</li> <li>4. Replace driver's air bag module. (Before disposal, it must be deployed.)</li> <li>5. Replace the diagnosis sensor unit.</li> <li>6. Replace the related harness.</li> </ol>		

# SUPPLEMENTAL RESTRAINT SYSTEM (SRS)

⊗ Trouble Diagnoses without CONSULT-II (Cont'd)

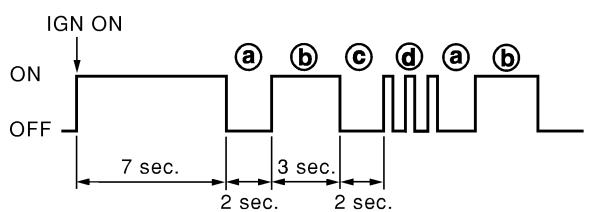
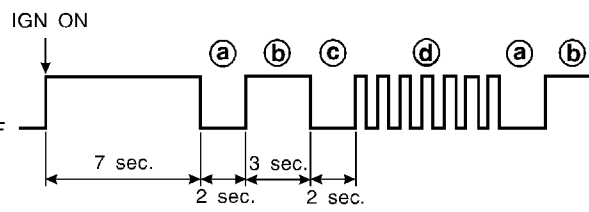
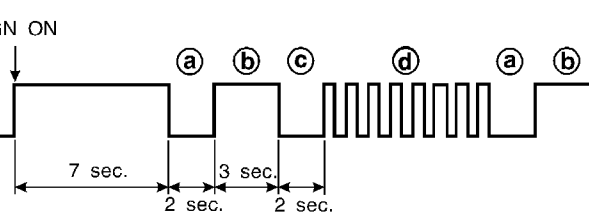
<p>The front LH seat belt pre-tensioner circuit is malfunctioning. (d: 3 flashes)</p>	<p style="text-align: center;">Flash pattern</p>  <p style="text-align: right;">SRS802</p>	<p>a through d are repeated. d — Three flashes indicate malfunctioning front LH pre-tensioner circuit.</p>
<p>Repair order ("Recheck SRS at each replacement.")</p>		
<ol style="list-style-type: none"> <li>1. Visually check the wiring harness connections.</li> <li>2. Replace the harness if it has visible damage.</li> <li>3. Replace front LH seat belt pre-tensioner. (Before disposing, it must be deactivated.)</li> <li>4. Replace the diagnosis sensor unit.</li> <li>5. Replace the related harness.</li> </ol>		
<p>The diagnosis sensor unit is malfunctioning. (d: 7 flashes)</p>	<p style="text-align: center;">Flash pattern</p>  <p style="text-align: right;">SRS335</p>	<p>a through d are repeated. d — Seven flashes indicate malfunctioning diagnosis sensor unit.</p>
<p>Repair order ("Recheck SRS at each replacement.")</p>		
<ol style="list-style-type: none"> <li>1. Visually check the wiring harness connections.</li> <li>2. Replace the harness if it has visible damage.</li> <li>3. Replace the diagnosis sensor unit.</li> <li>4. Replace the related harness.</li> </ol>		
<p>The front passenger air bag module circuit is malfunctioning. (d: 8 flashes)</p>	<p style="text-align: center;">Flash pattern</p>  <p style="text-align: right;">SRS336</p>	<p>a through d are repeated. d — Eight flashes indicate malfunctioning front passenger air bag module circuit.</p>
<p>Repair order ("Recheck SRS at each replacement.")</p>		
<ol style="list-style-type: none"> <li>1. Visually check the wiring harness connection.</li> <li>2. Replace the harness if it has visible damage.</li> <li>3. Replace front passenger air bag module. (Before disposal, it must be deployed.)</li> <li>4. Replace the diagnosis sensor unit.</li> <li>5. Replace the related harness.</li> </ol>		

# SUPPLEMENTAL RESTRAINT SYSTEM (SRS)

Trouble Diagnoses without CONSULT-II (Cont'd)

<p>The side air bag module (RH) circuit is malfunctioning. (f: 1 flash)</p>	<p style="text-align: center;">Flash pattern</p> <p>a through f are repeated. f — One flash indicates malfunctioning side air bag module (RH) circuit.</p> <p style="text-align: right;">SRS338</p>	<p>GI MA EM</p>
<p>Repair order ("Recheck SRS at each replacement.")</p> <ol style="list-style-type: none"> <li>1. Visually check the wiring harness connection.</li> <li>2. Replace the harness if it has visible damage.</li> <li>3. Replace side air bag module (RH). (Before disposal, it must be deployed.)</li> <li>4. Replace the diagnosis sensor unit.</li> <li>5. Replace the related harness.</li> </ol>		<p>LC EC FE</p>
<p>The side air bag module (LH) circuit is malfunctioning. (f: 2 flashes)</p>	<p style="text-align: center;">Flash pattern</p> <p>a through f are repeated. f — Two flashes indicate malfunctioning side air bag module (LH) circuit.</p> <p style="text-align: right;">SRS337</p>	<p>CL MT AT</p>
<p>Repair order ("Recheck SRS at each replacement.")</p> <ol style="list-style-type: none"> <li>1. Visually check the wiring harness connection.</li> <li>2. Replace the harness if it has visible damage.</li> <li>3. Replace side air bag module (LH). (Before disposal, it must be deployed.)</li> <li>4. Replace the diagnosis sensor unit.</li> <li>5. Replace the related harness.</li> </ol>		<p>AX SU BR</p>
<p>The satellite sensor (RH) is malfunctioning. (f: 3 flashes)</p>	<p style="text-align: center;">Flash pattern</p> <p>a through f are repeated. f — Three flashes indicate malfunctioning satellite sensor (RH) circuit.</p> <p style="text-align: right;">SRS340</p>	<p>ST RS BT</p>
<p>Repair order ("Recheck SRS at each replacement.")</p> <ol style="list-style-type: none"> <li>1. Visually check the wiring harness connection.</li> <li>2. Replace the harness if it has visible damage.</li> <li>3. Replace the satellite sensor (RH).</li> <li>4. Replace the diagnosis sensor unit.</li> <li>5. Replace the related harness.</li> </ol>		<p>HA SC EL</p>

# SUPPLEMENTAL RESTRAINT SYSTEM (SRS)

⊗ Trouble Diagnoses without CONSULT-II (Cont'd)

<p>The satellite sensor (LH) is malfunctioning. (f: 4 flashes)</p>	Flash pattern	
		<p>a through f are repeated. f — Four flashes indicate malfunctioning satellite sensor (LH) circuit.</p>
	SRS339-A	
<p>Repair order ("Recheck SRS at each replacement.")</p> <ol style="list-style-type: none"> <li>1. Visually check the wiring harness connection.</li> <li>2. Replace the harness if it has visible damage.</li> <li>3. Replace the satellite sensor (LH).</li> <li>4. Replace the diagnosis sensor unit.</li> <li>5. Replace the related harness.</li> </ol>		

\* Follow the procedures in numerical order when repairing malfunctioning parts. Confirm whether malfunction is eliminated using the air bag warning lamp or CONSULT-II each time repair is finished. If malfunction is still observed, proceed to the next step. When malfunction is eliminated, further repair work is not required.

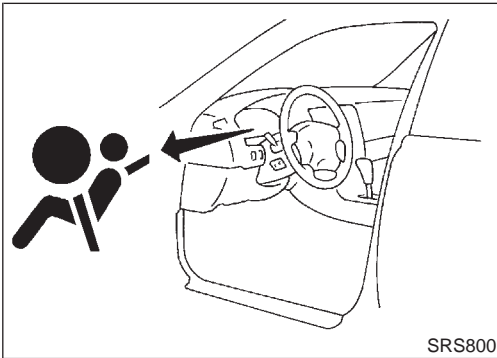

## DIAGNOSTIC PROCEDURE 7

Final checking after repairing SRS by using "AIR BAG" warning lamp — Diagnosis mode and User mode NFRS0049S02

1. After repairing SRS connect both battery cables.
2. Open driver's door.
3. Turn ignition switch from "OFF" to "ON".
4. "AIR BAG" warning lamp operates in Diagnosis mode as follows:



# SUPPLEMENTAL RESTRAINT SYSTEM (SRS)

⊗ Trouble Diagnoses without CONSULT-II (Cont'd)

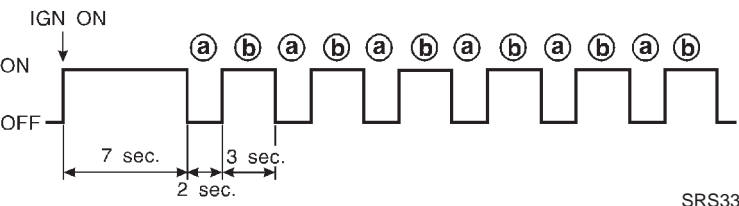
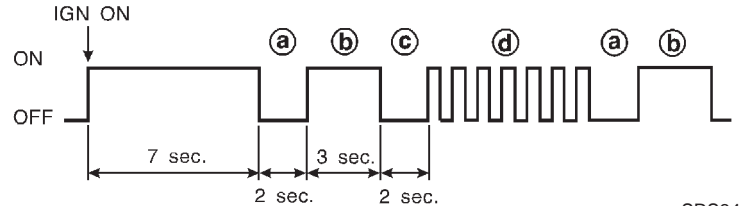
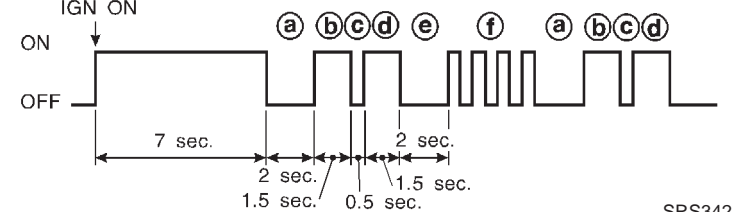
No.	"AIR BAG" warning lamp flash pattern — Diagnosis mode —	SRS condition
1	 <p style="text-align: right;">SRS333</p>	<p>a through b are repeated.</p> <p>No malfunction is detected or repair is completed. No further action is necessary.</p>
2	 <p style="text-align: right;">SRS341</p>	<p>a through d are repeated.</p> <p><b>b</b> — Driver and passenger air bag and seat belt pre-tensioner (For identifying driver air bag, passenger air bag and/or seat belt pre-tensioners malfunctioning)</p> <p><b>d</b> — Indicates malfunctioning part. The number of flashes varies with malfunctioning part (0.5 sec. ON and 0.5 sec. OFF is counted as one flash.)</p> <p>The system is malfunctioning and needs to be repaired.</p>
3	 <p style="text-align: right;">SRS342-A</p>	<p>a through f are repeated.</p> <p><b>b, c, d</b> — Side air bag marker (For identifying side air bag malfunctioning)</p> <p><b>f</b> — Indicates malfunctioning part. The number of flashes varies with malfunctioning part (0.5 sec. ON and 0.5 sec. OFF is counted as one flash.)</p>

## NOTE:

When diagnosis sensor unit is replaced with new one, "AIR BAG" warning lamp will operate in User mode. Checking "AIR BAG" warning lamp operation in Diagnosis mode is not required. Go to step 6.

5. If "AIR BAG" warning lamp operates as shown in No. 1 in chart above, turn ignition switch "OFF" to reset from Diagnosis mode to User mode and to erase the memory of the malfunction. Then go to step 6.

If "AIR BAG" warning lamp operates as shown in No. 2 or No. 3 in chart above, the malfunctioning part is not repaired completely, or another malfunctioning part is detected. Go to DIAGNOSTIC PROCEDURE 6, page RS-51, and repair malfunctioning part completely.

6. Turn ignition switch "ON". "AIR BAG" warning lamp operates in User mode. Compare "AIR BAG" warning lamp operation to the chart below.

## NOTE:



If switching Diagnosis mode to User mode is required while malfunction is being detected, by turning ignition switch as follows:

- 1) Turn ignition switch "ON".
- 2) After "AIR BAG" warning lamp lights for 7 seconds, turn ignition switch "OFF" within 1 second.
- 3) Wait more than 3 seconds.
- 4) Repeat steps 1 to 3 three times.
- 5) Turn ignition switch "ON".

SRS is now in User mode.

# SUPPLEMENTAL RESTRAINT SYSTEM (SRS)

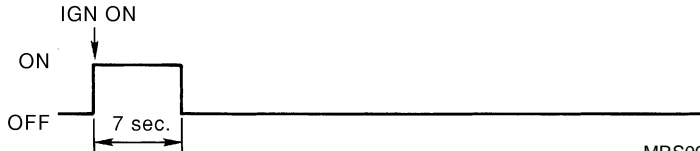
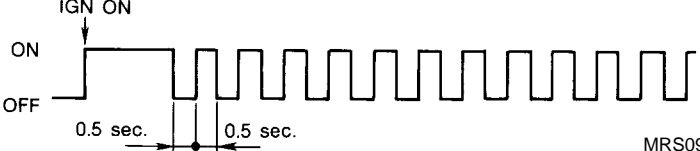
⊗ Trouble Diagnoses without CONSULT-II (Cont'd)

"AIR BAG" warning lamp operation — User mode —	SRS condition	Reference item
 <p>MRS095A</p>	<p>No malfunction is detected. No further action is necessary.</p>	<p>—</p>
 <p>MRS096A</p>	<p>The system is malfunctioning and needs to be repaired as indicated.</p>	<p>Go to DIAGNOSTIC PROCEDURE 6 (RS-51).</p>
 <p>MRS097A</p>	<p>Air bag is deployed. Seat belt pre-tensioner is deployed.</p> <p>Air bag fuse, diagnosis sensor unit or harness is malfunctioning and needs to be repaired.</p>	<p>Go to COLLISION DIAGNOSIS (RS-62).</p> <p>Go to DIAGNOSTIC PROCEDURE 9 (RS-59).</p>
 <p>MRS098A</p>	<p>One of the following has occurred and needs to be repaired.</p> <ul style="list-style-type: none"> <li>• Meter fuse is blown.</li> <li>• "AIR BAG" warning lamp circuit has open or short.</li> <li>• Diagnosis sensor unit is malfunctioning.</li> </ul>	<p>Go to DIAGNOSTIC PROCEDURE 10 (RS-61).</p>

## DIAGNOSTIC PROCEDURE 8 (CONTINUED FROM DIAGNOSTIC PROCEDURE 6)

NFRS0049S03

### Inspecting SRS malfunctioning record

<b>1</b>	<b>CONSIDER POSSIBILITY OF NOT ERASING SELF-DIAGNOSTIC RESULT AFTER REPAIRING</b>	
Is it the first time for maintenance of SRS?		
<b>Yes or No</b>		
Yes	▶	Go to DIAGNOSTIC PROCEDURE 5 (RS-47). (Further inspection cannot be performed without CONSULT-II.)
No	▶	Diagnosis results (previously stored in the memory) might not be erased after repair. Go to DIAGNOSTIC PROCEDURE 7, step 5 (RS-56).

# SUPPLEMENTAL RESTRAINT SYSTEM (SRS)

Trouble Diagnoses: "AIR BAG" Warning Lamp Does Not Turn Off



## Trouble Diagnoses: "AIR BAG" Warning Lamp Does Not Turn Off

=NFRS0050

NFRS0050S01

### DIAGNOSTIC PROCEDURE 9

<b>1</b>	<b>SEE THE DEPLOYMENT OF AIR BAG MODULE</b>	
Is air bag module deployed?		
<b>Yes or No</b>		
Yes	▶	Refer to COLLISION DIAGNOSIS (RS-62).
No	▶	GO TO 2.

<b>2</b>	<b>CHECK AIR BAG FUSE</b>																															
Is SRS "Air Bag" fuse OK?																																
 UP SIDE		SRS707																														
<table border="1" style="margin: auto;"> <tr><td></td><td></td><td></td><td></td><td></td><td></td><td></td><td></td><td></td><td></td></tr> <tr><td></td><td></td><td></td><td></td><td></td><td></td><td style="text-align: center;">AIR BAG</td><td></td><td></td><td></td></tr> <tr><td></td><td></td><td></td><td></td><td></td><td></td><td></td><td></td><td></td><td></td></tr> </table>																			AIR BAG													
						AIR BAG																										
<b>OK or NG</b>																																
OK	▶	GO TO 4.																														
NG	▶	GO TO 3.																														

<b>3</b>	<b>CHECK AIR BAG FUSE AGAIN</b>	
Replace "AIR BAG" fuse and turn ignition switch ON.		
<b>Is "AIR BAG" fuse blown again?</b>		
Yes	▶	Repair main harness.
No	▶	<b>INSPECTION END</b>

GI  
MA  
EM  
LC  
EC  
FE  
CL  
MT  
AT  
AX  
SU  
BR  
ST  
BT  
HA  
SC  
EL  
IDX

**RS**

# SUPPLEMENTAL RESTRAINT SYSTEM (SRS)

*Trouble Diagnoses: "AIR BAG" Warning Lamp Does Not Turn Off (Cont'd)*

<b>4</b>	<b>CHECK DIAGNOSIS SENSOR UNIT</b>									
<p>Ⓟ Connect CONSULT-II and touch "START".</p> <ul style="list-style-type: none"> <li>● Is "AIR BAG" displayed on CONSULT-II?</li> </ul>										
<table border="1" style="margin: auto; border-collapse: collapse;"> <tr><td style="text-align: center;">SELECT SYSTEM</td></tr> <tr><td style="text-align: center;">ENGINE</td></tr> <tr><td style="text-align: center;">A/T</td></tr> <tr><td style="text-align: center;">AIR BAG</td></tr> <tr><td style="text-align: center;"> </td></tr> <tr><td style="text-align: center;"> </td></tr> <tr><td style="text-align: center;"> </td></tr> <tr><td style="text-align: center;"> </td></tr> </table>			SELECT SYSTEM	ENGINE	A/T	AIR BAG				
SELECT SYSTEM										
ENGINE										
A/T										
AIR BAG										
SRS771										
<b>Yes or No</b>										
Yes	▶	GO TO 5.								
No	▶	Visually check the wiring harness connection of diagnosis sensor unit. If the harness connection check result is OK, replace diagnosis sensor unit.								

<b>5</b>	<b>CHECK HARNESS CONNECTION</b>	
Is harness connection between warning lamp and diagnosis sensor unit OK?		
<b>OK or NG</b>		
OK	▶	Replace diagnosis sensor unit.
NG	▶	Connect "AIR BAG" warning lamp and diagnosis sensor unit connector properly. If "AIR BAG" warning lamp still does not go off, replace harness.

# SUPPLEMENTAL RESTRAINT SYSTEM (SRS)

Trouble Diagnoses: "AIR BAG" Warning Lamp Does Not Turn On

## Trouble Diagnoses: "AIR BAG" Warning Lamp Does Not Turn On

=NFRS0051

NFRS0051S01

### DIAGNOSTIC PROCEDURE 10

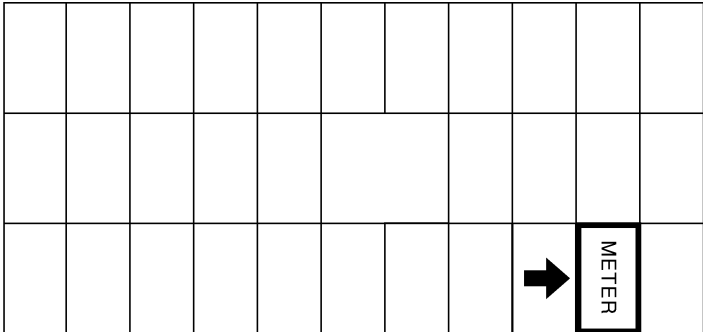
<b>1</b>	<b>CHECK "METER" FUSE</b>	
Is meter fuse OK?		
 UP SIDE		SRS774
<b>OK or NG</b>		
OK	▶	GO TO 3.
NG	▶	GO TO 2.

<b>2</b>	<b>CHECK "METER" FUSE AGAIN</b>	
Replace meter fuse and turn ignition switch ON.		
<b>Is meter fuse blown again?</b>		
Yes	▶	Repair main harness.
No	▶	<b>INSPECTION END</b>

<b>3</b>	<b>CHECK "AIR BAG" WARNING LAMP LED</b>	
Is "AIR BAG" warning lamp LED OK?		
<b>OK or NG</b>		
OK	▶	GO TO 4.
NG	▶	Replace "AIR BAG" warning lamp LED.

<b>4</b>	<b>CHECK HARNESS CONNECTION BETWEEN DIAGNOSIS SENSOR UNIT AND "AIR BAG" WARNING LAMP</b>	
Disconnect diagnosis sensor unit connector and turn ignition switch "ON".		
● Does "AIR BAG" warning lamp turn on?		
<b>Yes or No</b>		
Yes	▶	Replace diagnosis sensor unit.
No	▶	Check the ground circuit of "AIR BAG" warning lamp.

GI  
MA  
EM  
LC  
EC  
FE  
CL  
MT  
AT  
AX  
SU  
BR  
ST  
RS  
BT  
HA  
SC  
EL  
IDX

# SUPPLEMENTAL RESTRAINT SYSTEM (SRS)

Collision Diagnosis

## Collision Diagnosis

=NFRS0033

NFRS0033S07

### FOR FRONTAL COLLISION

To repair the SRS, perform the following steps.

#### When SRS (except the side air bag) is activated in a collision:

- 1) Replace the diagnosis sensor unit.
- 2) Remove the air bag modules (except the side air bag module) and seat belt pre-tensioner assemblies.
- 3) Check the SRS components using the table shown below:
  - Replace any SRS components showing visible signs of damage (dents, cracks and deformation).
- 4) Install new air bag modules (except the side air bag module) and seat belt pre-tensioner assemblies.
- 5) Conduct self-diagnosis using CONSULT-II or "AIR BAG" warning lamp. Refer to "SRS Operation Check" for details (RS-41). Ensure entire SRS operation properly.

#### When SRS is not activated in a collision:

- 1) Check the SRS components using the table shown below:
  - Replace any SRS components showing visible signs of damage (dents, cracks and deformation).
- 2) Conduct self-diagnosis using CONSULT-II or "AIR BAG" warning lamp. Refer to "SRS Operation Check" for details (RS-41). Ensure entire SRS operation properly.

### SRS Inspection (For frontal collision)

NFRS0033S0701

Part	SRS is activated	SRS is NOT activated
Air bag module (driver and passenger side)	REPLACE Install with new special bolts coated with bonding agent.	<ol style="list-style-type: none"> <li>1. Remove air bag module. Check harness cover and connectors for damage, terminals for deformities, and harness for binding.</li> <li>2.                             <ol style="list-style-type: none"> <li>a. Install driver air bag module into the steering wheel to check fit and alignment with the wheel.</li> <li>b. Install passenger air bag module into the instrument panel to check fit with the instrument panel.</li> </ol> </li> <li>3. No damage found, reinstall with new bolts coated with bonding agent.</li> <li>4. If damaged—REPLACE. Install air bag modules with new special bolts coated with bonding agent. Air bag must be deployed before discarding.</li> </ol>
Seat belt pre-tensioner assembly	REPLACE Install seat belt pre-tensioner with new bolts.	<ol style="list-style-type: none"> <li>1. Remove seat belt pre-tensioners. Check harness cover and connectors for damage, terminals for deformities, and harness for binding.</li> <li>2. Check belts for damage and anchors for loose mounting.</li> <li>3. Check retractor for smooth operation.</li> <li>4. If no damage is found, reinstall seat belt pre-tensioner assembly.</li> <li>5. If damaged—REPLACE. Install the seat belt pre-tensioners with new bolts coated with bonding agent. Seat belt pre-tensioners must be deployed before discarding.</li> </ol>
Diagnosis sensor unit	REPLACE Install with new bolts coated with bonding agent.	<ol style="list-style-type: none"> <li>1. Check case for dents, cracks or deformities.</li> <li>2. Check connectors for damage, and terminals for deformities.</li> <li>3. If no damage is found, reinstall with new special bolts and ground bolt coated with bonding agent.</li> <li>4. If damaged—REPLACE. Install diagnosis sensor unit with new special bolts and ground bolt coated with bonding agent.</li> </ol>
Steering wheel		<ol style="list-style-type: none"> <li>1. Visually check steering wheel for deformities.</li> <li>2. Check harness (built into steering wheel) and connectors for damage, and terminals for deformities.</li> <li>3. Install air bag module to check fit or alignment with steering wheel.</li> <li>4. Check steering wheel for excessive free play.</li> <li>5. If no damage is found, reinstall with bolts.</li> <li>6. If damaged—REPLACE.</li> </ol>
Spiral cable		<ol style="list-style-type: none"> <li>1. Visually check spiral cable and combination switch for damage.</li> <li>2. Check connectors and protective tape for damage.</li> <li>3. Check steering wheel for noise, binding or heavy operation.</li> <li>4. If no damage is found, reinstall with bolts.</li> <li>5. If damaged—REPLACE.</li> </ol>

# SUPPLEMENTAL RESTRAINT SYSTEM (SRS)

Collision Diagnosis (Cont'd)

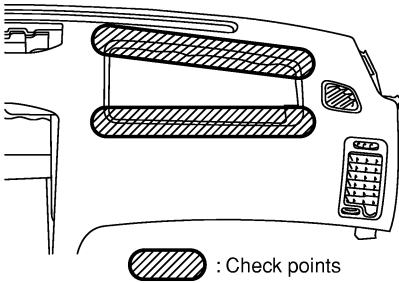
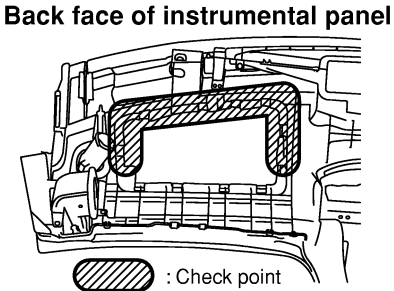
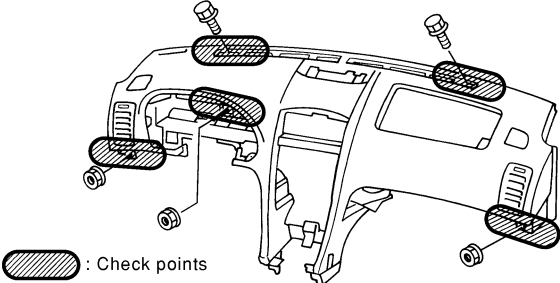
Part	SRS is activated	SRS is NOT activated
Harness and Connectors	<ol style="list-style-type: none"> <li>Check connectors for poor connection, damage, and terminals for deformities.</li> <li>Check harness for binding, chafing, cuts, or deformities.</li> <li>If no damage is found, reinstall the harness and connectors.</li> <li>Damaged—REPLACE damaged section of harness. Do not attempt to repair, splice or modify any SRS harness.</li> </ol>	
Instrument panel	<ol style="list-style-type: none"> <li>When passenger air bag inflates, check the following points for bending, deformities or cracks.                             <ul style="list-style-type: none"> <li>Opening portion for passenger air bag                                     <div data-bbox="727 436 1123 716">  <p>: Check points</p> </div> </li> <li>Passenger air bag module brackets                                     <div data-bbox="732 764 1123 1052"> <p><b>Back face of instrumental panel</b></p>  <p>: Check point</p> </div> </li> <li>The portions securing the instrument panel                                     <div data-bbox="646 1108 1203 1388">  <p>: Check points</p> </div> </li> </ul> </li> <li>If no damage is found, reinstall the instrument panel.</li> <li>If damaged—REPLACE the instrument panel with bolts.</li> </ol>	

GI  
MA  
EM  
LC  
EC  
FE  
SRS794  
CL  
MT  
AT  
AX  
SRS795  
SU  
BR  
ST  
RS  
BT  
HA  
SC  
EL  
IDX

# SUPPLEMENTAL RESTRAINT SYSTEM (SRS)

Collision Diagnosis (Cont'd)

## FOR SIDE COLLISION

=NFRS0033S08

To repair the SRS for a side collision, perform the following steps.

### When the side air bag is activated in the side collision:

- 1) Replace the following component:
  - All parts of seatback (including seatback frame) with side air bag module (on the side on which side air bag is activated)
  - Diagnosis sensor unit
  - Satellite sensor (on the side on which side air bag is activated)
- 2) Check the SRS components and the related parts using the table shown below.
  - Replace any SRS components and the related parts showing visible signs of damage (dents, cracks, deformation).
- 3) Conduct self-diagnosis using CONSULT-II or "AIR BAG" warning lamp. Refer to "SRS Operation Check" for details (RS-41). Ensure entire SRS operation properly.

### When SRS is not activated in the side collision:

- 1) Check the SRS components and the related parts using the table shown below.
  - Replace any SRS components and the related parts showing visible signs of damage (dents, cracks, deformation).
- 2) Conduct self-diagnosis using CONSULT-II or "AIR BAG" warning lamp. Refer to "SRS Operation Check" for details (RS-41). Ensure entire SRS operation properly.

### SRS Inspection (For side collision)

NFRS0033S0801

Part	Side air bag is activated	SRS is NOT activated
Built-in type side air bags module (LH or RH)	REPLACE all parts of seat back with deployed side air bag module.	<ol style="list-style-type: none"> <li>1. Check for visible signs of damage (dents, tears, deformation) of the seat back on the collision side.</li> <li>2. If damaged—REPLACE the damaged seat parts with new bolts and remove the side air bag module.</li> <li>3. Check for visible signs of damaged (tesrs etc.) of the side air bag module.</li> <li>4. Check harness and connectors for damage, and terminals for deformities.</li> <li>5. If no damaged is found, reinstall the side air bag module with new torx nuts coated with bonding agent.</li> <li>6. If damaged—REPLACE the side air bag module with new torx nuts coated with bonding agent. Air bag must be deployed before disposing of it.</li> </ol>
Satellite sensor (LH or RH)	REPLACE the satellite sensor on the collision side with new nuts coated with bonding agent. (Repair the center pillar inner, etc. before installing new one if damaged.)	<ol style="list-style-type: none"> <li>1. Remove the satellite sensor on the collision side. Check harness connectors for damage, terminals for deformities, and harness for binding.</li> <li>2. Check for visible signs of damage (dents, cracks, deformation) of the satellite sensor.</li> <li>3. Install the satellite sensor to check fit.</li> <li>4. If no damage is found, reinstall the satellite sensor with new nuts coated with bonding agent.</li> <li>5. If damaged—REPLACE the satellite sensor with new nuts coated with bonding agent.</li> </ol>
Diagnosis sensor unit	REPLACE the diagnosis sensor unit with the new bolts.	<ol style="list-style-type: none"> <li>1. Check case and bracket for dents, cracks or deformities.</li> <li>2. Check connectors for damage, and terminals for deformities.</li> <li>3. If no damage is found, reinstall the diagnosis sensor unit with new special bolts and ground bolt.</li> <li>4. If damaged—REPLACE. Install the diagnosis sensor unit with new special bolts and ground bolt.</li> </ol>
Seat belt pre-tensioner assembly		<ol style="list-style-type: none"> <li>1. Check if the seat belt can be extended smoothly. If the seat belt cannot be extended smoothly.                             <ul style="list-style-type: none"> <li>– Check for deformities of the center pillar inner.</li> <li>– If the center pillar inner has no damage, REPLACE the seat belt pre-tensioner assembly.</li> </ul> </li> <li>2. Remove the seat belt pre-tensioner assembly on the collision side. Check harness cover and connectors for damage, terminals for deformities, and harness for binding.</li> <li>3. Check for visible signs of damage (dents, cracks, deformation) of the seat belt pre-tensioner assembly.</li> <li>4. If no damage is found, reinstall the seat belt pre-tensioner assembly.</li> <li>5. If damaged—REPLACE the seat belt pre-tensioner assembly with new bolts coated with bonding agent. The seat belt pre-tensioner assembly must be deployed before disposing of it.</li> </ol>



# SUPPLEMENTAL RESTRAINT SYSTEM (SRS)

Collision Diagnosis (Cont'd)

Part	Side air bag is activated	SRS is NOT activated	
Seat	REPLACE all parts of seat back (including seat back frame)	<ol style="list-style-type: none"> <li>1. Visually check the seat on the collision side.</li> <li>2. Remove the seat on the collision side and check the following for damage and deformities.                             <ul style="list-style-type: none"> <li>● Harness, connectors and terminals</li> <li>● Frame and recliner (for front and rear seat), and also adjuster and slides (for front seat)</li> </ul> </li> <li>3. If no damage is found, reinstall the seat.</li> <li>4. If damaged—REPLACE the damaged seat parts with new bolts.</li> </ol>	GI MA EM
Center pillar inner		<ol style="list-style-type: none"> <li>1. Check the center pillar inner on the collision side for damage (dents, cracks, deformation).</li> <li>2. If damaged—REPAIR the center pillar inner.</li> </ol>	LC
Trim		<ol style="list-style-type: none"> <li>1. Check for visible signs of damage (dents, cracks, deformation) of the interior trim on the collision side.</li> <li>2. If damaged—REPLACE the damaged trim parts.</li> </ol>	EC
			FE
			CL
			MT
			AT
			AX
			SU
			BR
			ST
			<b>RS</b>
			BT
			HA
			SC
			EL
			IDX

## NOTES